



RTS110 SERIES TOTAL STATION

Instruction Manual (Ver1.2e)



Suzhou FOIF Co.,Ltd.

Foreword

Thanks for you purchasing the FOIF TS110 series total station. In order to use the instrument well, please read this instruction manual carefully and keep it cautiously for consulting in the further.

Product confirmation:

Please fill the model and the serial number of your instrument in corresponding blank. Feedback to local distributor or our sales department.

NOTE :

- Please read this instruction manual carefully before use it.
- Avoiding insulates the instrument, and don't collimate the sun directly for protecting eyes and instrument.
- When using it please insure the connection between tripod and instrument is firm. If raining, you can hood it with rainproof cover.
- Please loose the clamp system when the instrument in the case, and keep the case dry.
- When transporting, keep the instrument in the case and try your best to lighten librations.
- After working in wet or raining condition, please wipe water on surface and keep it in air, when it is dry completely, you can put it in the case.
- Don't clean the instrument surface with alcohol, aether or other irritant chemical things; and use the equipped paper to clean the optical parts.
- If you do not use the instrument for a long time, you should take the battery pack down and recharge once every month.
- If you do not use the instrument for a long time, take the instrument out of the case and keep it in the dry condition.
- If the temperature changing is sharp (for example: move it out from one hot vehicle), the measured data will be influenced, so it can be used when it adapts the surrounding condition.
- Before use it, you should check the voltage for whether it is enough.
- Do not remove the battery at working time, otherwise some settings or measured data may be lost.

Safety Cautions:

- **There is a risk of fire, electric shock or physical harm if you attempt to disassemble or repair the instrument yourself.**

This is only to be carried out by FOIF or an authorized dealer, only!

- **Cause eye injury or blindness.**

Do not look at the sun through a telescope.

- **Laser beams can be dangerous, and can cause eye injury if used incorrectly.**

Never attempt to repair the instrument yourself.

- **Cause eye injury or blindness.**

Do not stare into laser beam.

- **High temperature may cause fire.**

Do not cover the charger while it is charging.

- **Risk of fire or electric shock.**

Do not use damaged power cable, plug and socket.

- **Risk of fire or electric shock.**

Do not use a wet battery or charger.

- **May ignite explosively.**

Never use an instrument near flammable gas, liquid matter, and do not use in a coal mine.

- **Battery can cause explosion or injury.**

Do not dispose in fire or heat.

- **Risk of fire or electric shock.**

Do not use any other type of charger other than the one specified.

- **Risk of fire.**

Do not use any other power cable other than the one specified.

- **The short circuit of a battery can cause a fire.**

Do not short circuit battery when storing it.

CAUTION!

- Do not connect or disconnect equipment with wet hands, you are at risk of electric shocks if you do!

- Risk of injury by overturn the carrying case.

Do not stand or sit on the carrying cases.

- Please note that the tips of tripod can be hazardous, be aware of this when setting up or carrying the tripod.

- Risk of injury by falling down the instrument or case.

Do not use a carrying case with a damaged which belts, grips or latches.

- Do not allow skin or clothing to come into contact with acid from the batteries, if this does occur then wash off with copious amounts of water and seek medical advice.

- Ensure that you mount the Tribrach correctly, failing to do so may result in injury if the tribrach were to fall over.

- It could be dangerous if the instrument falls over, please check that you fix the instrument to the tripod correctly.

- Risk of injury by falling down a tripod and an instrument.

Always check that the screws of tripod are tightened.

- It could cause measurement error when there is leave or other object between instrument and target.

User

1. This product is for professional use only!

The user is required to be a qualified surveyor or have a good knowledge of surveying, in order to understand the user manual and safety instructions, before operating, inspecting or adjusting.

2. Wear the required protectors (safety shoes, helmet, etc.) when operating.

Exceptions from Responsibility

- 1) The user of these products is expected to follow all operating instructions and make periodic checks of the product's performance.
- 2) The manufacturer, assumes no responsibility for results of a faulty or intentional usage or misuse including any direct, indirect, consequential damage, and loss of profits.
- 3) The manufacturer assumes no responsibility for consequential damage, and loss of profits by any disaster, (an earthquake, storms, floods etc.).
- 4) The manufacturer assumes no responsibility for any damage, and loss of profits due to a change of data, loss of data, an interruption of business etc., caused by using the product or an unusable product.
- 5) The manufacturer assumes no responsibility for any damage, and loss of profits caused by usage except for explained in the user manual.
- 6) The manufacturer assumes no responsibility for damage caused by wrong transport, or action due to connecting with other products.

Safety Standards for OTS110 EDM Laser (OTS110 series)

OTS110 series adopt the class of Laser Product according to IEC Standard Publication 60825-1 Amd. 2:2001. According this standard, EDM device is classified as Class 3R Laser Product when reflectless measurement is selected, when the prism and reflective sheet is selected as target, the output is equivalent to the safer class 1. Follow the safety instructions on the labels to ensure safe use.

CAUTION: CLASS 3R LASER RADIATION WHEN OPEN
AVOID DIRECT EYE EXPOSURE.

CAUTION: CLASS 1 LASER RADIATIONS WHEN OPEN
DO NOT STARE INTO THE BEAM

Note for Safety



WARNING

- Never point the laser beam at other's eyes, it could cause serious injury.
- Never look directly into the laser beam source, it could cause permanent eye damage.
- Never stare at the laser beam, it could cause permanent eye damage.
- Never look at the laser beam through a telescope or other optical devices, it could cause permanent eye damage.

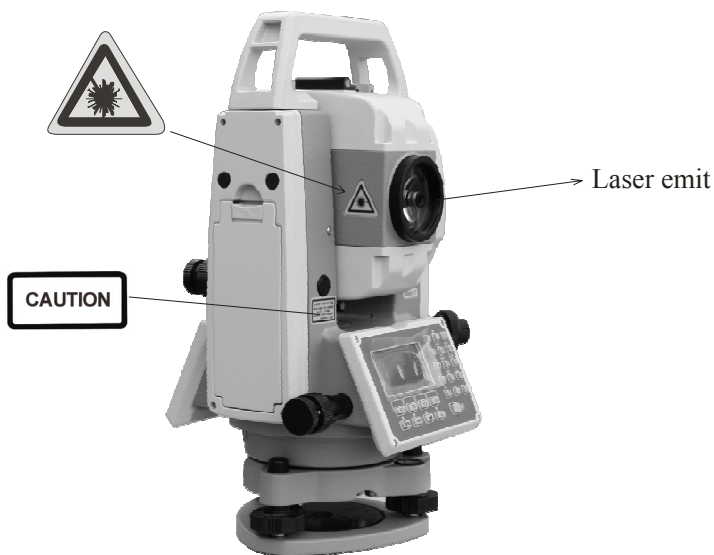

Content

Applications	1
1. Nomenclature and functions	2
1.1 Nomenclature	2
1.2 Display	3
1.3 Operating Key	6
1.4 Function key (Soft Key).....	7
2. Battery.....	9
2.1 Mounting the battery.....	9
2.2 Recharge	10
3. Preparation for measurement	11
3.1 Setting up the instrument	11
3.2 Leveling the instrument	11
3.3 Centering.....	12
3.3.1 Centering with optical plummet.....	12
3.3.2 Centering with laser plummet (Factory Optional)	
.....	12
3.4 Focusing.....	13
3.5 Switch on	13
3.6 Switch off.....	14
3.7 The function of ★ key menu	14
3.8 How to input number and letter	16
3.9 Vertical Angle Tilt Correction	17
4. Angle Measurement	18
4.1 Measuring Horizontal Angle (Right) and Vertical Angle..	18
4.2 Switching Horizontal Angle Right/ Left.....	19
4.3 Set a Horizontal Angle.....	20
4.4 Vertical Angle Grade Mode Switch.....	22
4.5 Zenith distance/ vertical angle mode switch	22
4.6 Set Buzzer Sounding for Horizontal Angle 90°	23

5. Distance Measurement	24
5.1 Distance Measurement (Slope distance mode).....	24
5.2 Distance Measurement (HD/VD mode)	25
5.3 Distance Offset Measurement	26
5.3.1 Angle offset measurement	26
5.3.2 Distance Offset Measurement	28
5.3.3 Plane Offset Measurement.....	30
5.3.4 Column Offset Measurement.....	32
5.4 Stake out (S.O)	34
5.5 Set distance measurement mode.....	35
5.6 Set distance unit.....	36
5.7 Setting of the Atmospheric Correction.....	37
5.8 Returned signal Checking.....	38
5.9 Setting distance measurement times (Factory setting is “3”)	39
6. Coordinate Measurement	40
6.1 Setting Coordinate of Occupied point	41
6.2 Setting of instrument height	42
6.3 Setting of target height	43
6.4 Setting coordinate of backsight point	44
6.5 Measuring point coordinate.....	45
7. Data collection.....	46
7.1 Data collection menu operation.....	46
7.2 Selecting a file for data collection	47
7.3 Selecting a coordinate file for data collection	48
7.4 Occupied Point Setting	49
7.5 Backsight Point.....	51
7.6 Operational Procedure of “Data Collect”	53
7.7 Setting PCODE for measured point.....	55
7.7.1 Entering PCODE / ID using PCODE Library	55

7.7.2	Entering PCODE / ID from the list of PCODE.....	56
7.8	Data Collect Offset Measurement mode.....	57
7.8.1	Angle offset measurement.....	57
7.8.2	Distance Offset Measurement.....	59
7.8.3	Plane Offset Measurement.....	61
7.8.4	Column Offset Measurement.....	63
7.9	NEZ Auto Calculation.....	65
7.10	Setting Parameter of Data Collect [CONFIG.].....	66
8.	Coordiante Layout.....	68
8.1	Layout procedures.....	68
8.2	Selecting or creating a coordinate data file.....	68
8.3	Occupied Point Setting.....	70
8.4	Setting Backsight Point.....	74
8.5	Executing a Layout.....	77
8.6	Setting the GRID FACTOR.....	80
9.	Application Measurement (Programs).....	82
9.1	Remote Elevation Measurement (REM).....	82
9.2	Missing Line Measurement (MLM).....	85
9.2.2	USE FILE and GRID FACTOR.....	88
9.2.3	Use coordinate for MLM program.....	89
9.3	Setting Z Coordinate of Occupied Point.....	90
9.4	Area Measurement.....	94
9.4.1	Area Calculation from Coordinate Data File.....	94
9.4.2	Area Calculation from measured data.....	95
9.5	Point to Line.....	97
9.6	Setting a new point.....	100
9.6.1	Side short method.....	100
9.6.2	Resection method.....	102
10.	Memory Manager Mode.....	106
10.1	Enter Memory Manager Mode.....	106

10.2	Display Internal Memory Status.....	107
10.3	Searching data	107
10.3.1	Measured data searching	107
10.3.2	Coordinate Data Searching.....	109
10.3.3	PCODE Library Searching	110
10.4	File Maintenance	111
10.4.1	Rename a file.....	112
10.4.2	Deleting a File	112
10.4.3	Searching Data in a File	113
10.5	Coordinate Data Direct Key input.....	113
10.6	Delete a Coordinate Data from a File.....	115
10.7	Editing PCODE Library	116
10.8	Data Transfer by serial port(Optional)	117
10.8.1	Sending data	117
10.8.2	Loading data.....	118
10.8.3	Setting parameter of data communications.....	119
10.9	Memory initialize	120
10.10	Connect PC via USB port.....	121
10.11	Copy the data files from memory to SD card (Optional)	
	123
10.12	Connect TS650 with other device via Bluetooth (Optional)	
	124
11.	Instrument Settings.....	125
11.1	Items of instrument settings.....	125
	(* factory setting)	126
11.2	Enter setting mode.....	127
11.3	Setting procedures	127
12.	Selecting Mode.....	128
12.1	Items of selecting mode.....	128
12.2	How to set selecting mode.....	132

13. Check and adjustment	134
13.1 Checking and adjusting of instrument constant	134
13.2 Checking/adjusting the plate level	136
13.3 Checking/adjusting the circular level Check.....	137
13.4 Checking/adjusting the optical sight.....	138
13.5 Checking/Adjusting the plummet	139
13.5.1 Checking/Adjusting the optical plummet Check	139
13.5.2 Checking/Adjusting the laser plummet (Optional accessory).....	140
13.6 Checking/Adjusting the vertical cross-hair on telescope	141
Adjustment.....	141
13.7 Checking/adjusting horizontal collimation error Check	142
13.8 Checking/adjusting of the vertical index error i.....	142
13.9 Checking the optical axis	145
14. Specifications.....	146
15. Packing list.....	153
Attachment 1: atmospheric correction formula and chart (for your reference).....	154
Attachment 2 Correction for refraction and earth curvature	157
Attached file 3: communication instruction and data format.....	158

Applications

FOIF TS110 series Total Station applied absolute encoder system to digital angle measurements, it adopt phases measurement system to measure distance. It can measure distance not only with prism but also with reflective sheet, so much as it can work without cooperate objective. It can achieve measurement, calculating, display and storage etc. by means of microcomputer-technology. It can display measuring results of horizontal, vertical angle and distance at the same time.

These series Total Station is designed for engineering items, especially for every construction area. It can be used in coordinate measurement or location measurement for construction, remote elevation measurement, plumb line surveying, ductwork surveying and sectional surveying etc. It also can be used in triangulation control survey, cadastral surveying, topographic surveying and house property surveying.

1. Nomenclature and functions

1.1 Nomenclature





RS232C&USB port
(Standard)



Mini USB port(Optional)
Bluetooth&SD card
slot(Optional)

1.2 Display

The display uses a dot matrix LCD/OLED (factory optional) which has 4 lines and 16 characters per line. In general, the upper three lines display measured data, and the bottom line displays the soft key function which changes with the measuring mode.

There are two type modes: measurement mode and menu mode.

◆ Measurement mode of TS110 series:

VZ: 81° 54' 21"
HR: 157° 33' 58"

OSET HOLD HSET P1

Angle measurement mode

Zenith distance: 81° 54' 21"

H-angle: 157° 33' 58"

VZ: 81° 54' 21"
HR: 157° 33' 58"
SD: 130.216m f

DIST MODE S/A P1

Distance measurement mode 1

Zenith distance: 81° 54' 21"

H-angle: 157° 33' 58"

Slope distance: 130.216 m

HR: 157° 33' 58"
HD: 128.919m
VD: 18.334m

DIST MODE S/A P1

Distance measurement mode 2

H-angle: 157° 33' 58"

H-distance: 128.919m

V-distance: 18.334 m

N: 5.868m
E: -3.308m
Z: 0.226m

DIST MODE S/A P1

Coordinate measurement mode

N: 5.868 m

E: -3.308 m

Z: 0.226 m

◆ Example of menu mode:

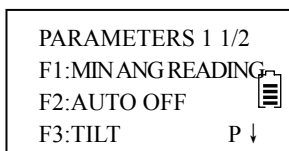
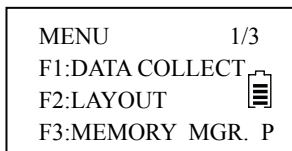

MENU(page 1,total 3)

Press F1 enter “data collect”

Press F2 enter “layout”

Press F3 enter “memory MGR.”

PARAMETERS

Press F1 enter “min.angle reading”

Press F2 enter “auto off”



Press F3 enter “tilt” for sensor

◆ Display mark

VZ	Zenith distance
VH	Height angle
V%	grade
HR/HL	H-angle right/H-angle left
SD/HD/VD	S-distance/H-distance/Height difference
N	N coordinate
E	E coordinate
Z	Z coordinate
PT#	Point number
ST/BS/SS	Measured station/Backsight/Collected point
Ins.Hi(I.HT)	Instrument height
Ref.Hr(R.HT)	Prism Height
PT#	Registered number of PCODE
PCODE	Point code
P1/P2/P3	Page 1/Page 2/Page 3

1.3 Operating Key



Keys	1st Function	2nd Function
F1-F4	Functions keys correspond message displayed	Functions keys correspond message displayed
0~9	Enter number	Enter letter or other character
ESC	Escape from menu	
★	Hot key for fast settings	
Ⓛ	Power on/off	
MENU	Enter menu	Cursor move left, return to previous page
ANG	Switches the angle measurement mode	Cursor move right return to next page
	Enter S-distance H-distance model measurement model	Cursor move up display previous point in memory
	Enter coordinate measurement model	Cursor move down display next point in memory

1.4 Function key (Soft Key)

The Soft Key function is displayed at the bottom line of display.
The function is changed with measurement mode.

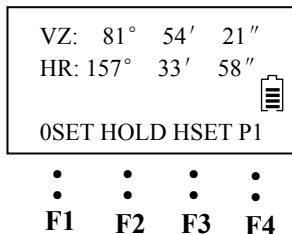

Function key

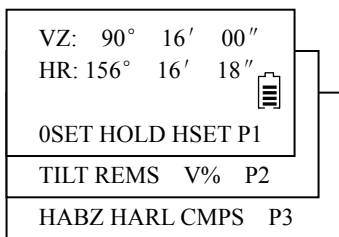

Angle measurement mode

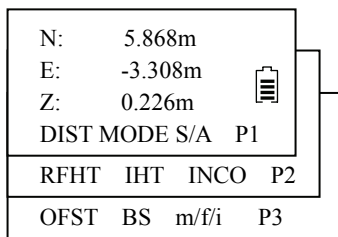

Coordinate measurement mode

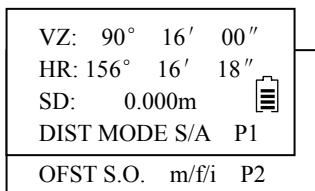

Slope distance measurement

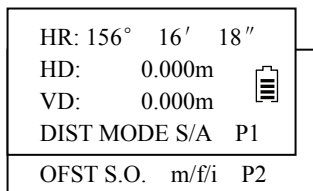

Horizontal distance measurement

Descriptions

Mode		Display mark	Soft key	Function
Angle measurement	P1	0SET	F1	Horizontal angle is set to 0
		HOLD	F2	Hold the horizontal angle
		HSET	F3	Setting horizontal angle by input values
	P2	TILT	F1	Setting tilt compensator on/off
		REMS	F2	Enter repeat angle measurement program
		V%	F3	Switch grade/zenith distance VZ
	P3	HABZ	F1	Buzzer set for every horizontal angle 90°
		HARL	F2	Switch horizontal angle mode (HR/HL)
		CMPS	F3	Set a vertical angle mode(VH/VZ)
S-distance meas.	P1	DIST	F1	Start distance measurement
		MODE	F2	Select the measurement model as fine or track
		S/A	F3	EDM setting
	P2	OFST	F1	Select Offset measurement program
		S.O.	F2	Select stake out measurement program
		m/f/i	F3	Change the display of distance unit
Coordinate meas.	P1	DIST	F1	Start distance measurement
		MODE	F2	Select the measurement model as fine or track
		S/A	F3	EDM setting
	P2	RFHT	F1	Set prism height
		IHT	F2	Set instrument height
		INCO	F3	Sets occupied station coordinate
	P3	OFST	F1	Enter offset measurement program
		BS	F2	Sets back sight point coordinate
		m/f/i	F3	Change the distance unit

2. Battery

2.1 Mounting the battery

(1) Insert the battery by aligning the battery pack's tenon with the notch in the instrument, press the battery clamp and push the top of the battery pack until you hear a click.

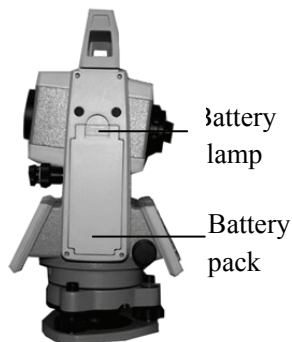

(2) Removing the battery

Press the battery clamp and remove the battery pack by pulling it toward you.

(3) Battery Indicator

Battery power display indicates the power condition. You should recharge or replace the battery when you hear the continue buzz. Please turn off in the normal way in order to save the data. Please find the battery operating time on Specifications.



Battery power display

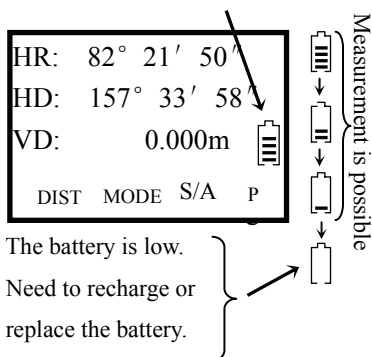

2.2 Recharge



1. Plug the charger on 100-240VAC (50-60Hz)

power supply, the red lamp lighting.

2. When recharge is complete, the light become green. Normally, it will take about 3-4 hours.

Caution: For indoor use only.

Note:

1. The new battery (or not be used for long time) need to recharge and discharge for several times, the battery could become the good performance for using. Please recharge more than 10 hours.
2. Please prolong charge 1-2 hours after green lamp lighting to reach the best performance.
3. Lamp situation: red lamp lighting--charging; green lamp lighting--charge complete; red lamp flash--waiting, not connecting or battery defective.
4. If the red lamp flashes when plug the charger, please remove the charger and wait a minute to plug it again.

3. Preparation for measurement

3.1 Setting up the instrument

(1) Setting up the tripod

First, extend the extension legs to suitable lengths and tighten the screws on the midsections

(2) Attaching the instrument on the tripod head

Place the instrument carefully on the tripod head and slide the instrument by loosening the tripod screw.

3.2 Leveling the instrument

(1) Leveling with the circular level by adjusting leveling screws A and B, position the bubble in the center of vial (Fig a).

Adjust the leveling screw C, position the bubble in the center of circle (Fig b).

(2) Leveling precisely by plate level
Loosen horizontal motion clamp, place the plate level in parallel with the line joining leveling screws A and B. Adjust the leveling screws A and B, position the bubble in the center of the plate level (Fig c).

Loosen horizontal motion clamp, rotate the plate level through 90° around the vertical axis. Adjust leveling screw C, position the bubble in the center of plate level (Fig d). Repeat above steps until the bubble remains in the center of plate level while the instrument is rotated to any position.

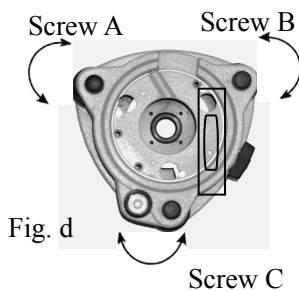
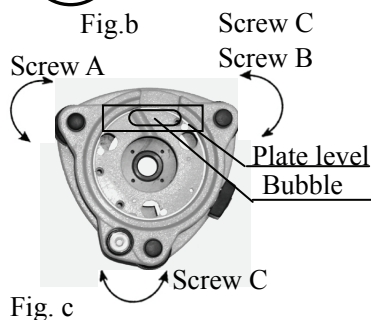
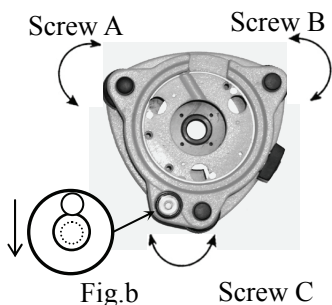
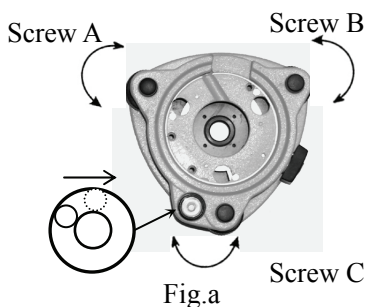

3.3 Centering

3.3.1 Centering with optical plummet

Leveling the instrument by plate level first. Rotate the focusing ring of the optical plummet and adjust the focus to the ground mark point. Then loosen the center screw of the tripod, look through the optical plummet, and move the base plate on the tripod head until the center mark coincides with the ground mark point. At last tighten the center screw.

Repeat above steps to leveling the instrument again, until the center of

reticle coincides with the mark point when rotating alidade of instrument.

3.3.2 Centering with laser plummet (Factory Optional)

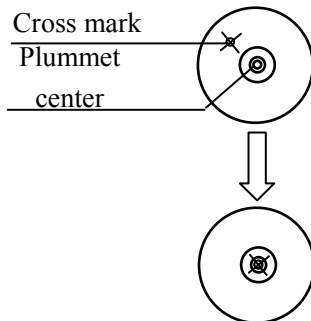
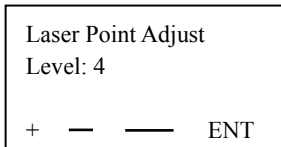
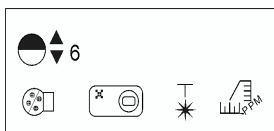

(1) Press ★ key to open fast setting menu, and press F3 to open plummet laser intensity adjusting menu, press F1 to increase laser intensity, or press F2 to decrease laser intensity, at last press F4(ENT) to confirm.

(2) Turn the focusing knob until the laser spot on the same horizontal plane with mark point on the ground.

(3) Loosen the center screw of the tripod, and move the base plate on the tripod head until the laser spot coincides with the ground mark point. Tighten the center screw.

(4) Repeat leveling and (3) steps until the instrument keeps leveling and the laser spot coincides with the mark point when rotating alidade of instrument to any direction.

(5) After centering, please press [ESC] key.

3.4 Focusing

(1) Diopter adjustment

Point telescope to sky or a uniformly light surface (Do not point to the sun). Turn eyepiece until cross hairs are sharp and black.

(2) Target image focusing

Look through telescope eyepiece and turn focusing ring until target is seen. There should be no apparent movement between cross hairs and target as observer moves his eye slightly. If there is parallax, please remove it by adjusting the focusing ring slightly.

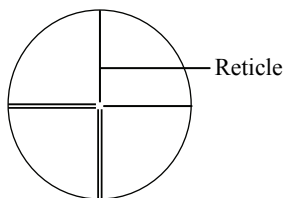

3.5 Switch on

1. Confirm the instrument is leveled and centered.

2. Press power key to switch on.

3. It will show the software version and date first, then to show LCD Contrast adjusting screen. It also shows current prism constant value (PSM) and atmospheric correction value (PPM). You could press F1 or F2 to adjust the contrast. Then press F4 to confirm and enter basic measurement mode.

Check the battery power indicator, recharge battery when battery level is low or indicates “battery empty”.

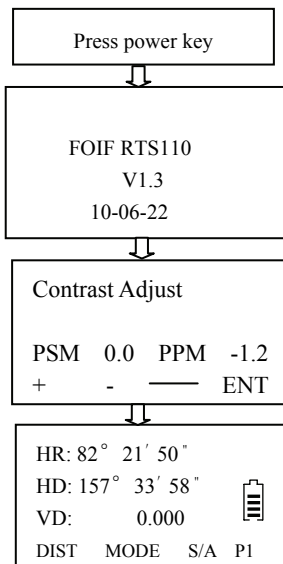

Flow chart for switch on

3.6 Switch off

- (1) Press power key.
- (2) Press F3 to switch off; Press F4 back to the latest mode.

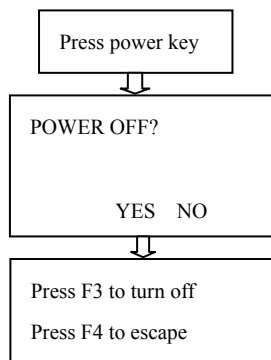



Flow chart for switch off

3.7 The function of ★ key menu

● RTS650 series

- (1) Display contrast adjusting ( 6)

Press ★ key, the display contrast will be higher if you press  (▲) key; and it will be lower if you press  (▼) key.

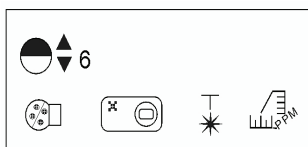

- (2) Illumination on/off ()

Press [F1] key to turn on/off reticle illumination and display backlight.

- (3) Tilt On/Off ()

Press ★ key and displaying the ★ menu. Press [F2] to display the tilt menu, the tilt will be on if you press [F1] key and it will be off if you press [F3] key.

- (4) Laser plummet intensity adjusting ()

Press ★ key and displaying the ★ menu. Press[F3] to display laser point adjust mode. Press [F1] or [F2] to level up or level down, press [F4] to confirm.

● OTS110 series



Icons	Functions	Operating keys
	Display contrast adjusting	▼ or ▲
	Target setting Prism/Sheet/Noprism	◀
	Laser pointer On/Off	▶
	Illumination on/off	F1
	Tilt sensor On/Off	F2
	Laser plummet intensity adjusting	F3
	EDM settings	F4

3.8 How to input number and letter

For TS110 series, the number and letter can input with keyboard directly.

Example: Create one file for data collect program

Operating procedure	Operation	Display
<p>①Enter the menu by press the [MENU] key.</p> <p>②Press [F1] key to enter file selecting screen, press the [F1](INPT) key to rename file name. And press [F1](ALPH) key to switch inputting mode from number to letter.</p> <p>③Input letter one by one ※1) Input “S” Input “U” Input “N” Input “-”</p> <p>④Press [F1](ALPH) key to switch inputting mode from letter to number. Input “01”</p> <p>⑤Press the [F4] key to confirm</p>	<p>[MENU]</p> <p>[F1]</p> <p>[F1]</p> <p>[F1]</p> <p>[1]</p> <p>[1][1][1]</p> <p>[5][5]</p> <p>[3][3][3]</p> <p>[F1]</p> <p>[0][1]</p>	<div style="border: 1px solid black; padding: 5px; margin-bottom: 5px;"> MENU 1/3 F1: DATA COLLECT F2: LAYOUT F3:MEMORY MGR. P </div> <div style="border: 1px solid black; padding: 5px; margin-bottom: 5px;"> SELECT A M.FILE FN: INPT LIST ENT </div> <div style="border: 1px solid black; padding: 5px; margin-bottom: 5px;"> SELECT A M.FILE FN: ALPH SPC CLR ENT </div> <div style="border: 1px solid black; padding: 5px;"> SELECT A M.FILE FN=SUN_01 /M0015 NUM SPC CLR ENT </div> <p>After input a number, the cursor will move backward automatically</p>
<p>※1) If one letter need to be input twice or more, after input the front letter, press the  key to move cursor, then input the following letter again.</p> <p>Press F2 (SPC) key to enter a space.</p> <p>Press F3[CLR]key, all the input characters will be deleted.</p>		

3.9 Vertical Angle Tilt Correction

When the tilt sensors are activated, automatic correction of vertical angle for mislevelment is displayed.

To ensure a precise angle measurement, tilt sensors should be turned on. The display can also be used to precise level the instrument. If the display(X Tilt over) appears the instrument is out of automatic compensation range and must be leveled manually.

The vertical angle display is unstable when instrument is on an unstable stage or a windy day. You can turn off the auto tilt correction function in this case.

Example: Setting Tilt OFF

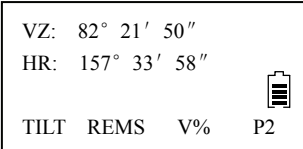
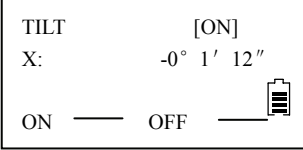
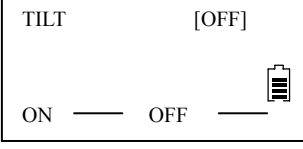
Operating procedure	Operation	Display
①Under Angle measurement mode, press[F4] to enter P2.	[F4]	
②Press [F1] key. In case ON is already selected, the display shows tilt correction value.※1)	[F1]	
③Press[F3](OFF) key. ④Press[ESC]key.	[F3] [ESC]	
<p>※1) The setting mode performed here will not be memorized after powering OFF. To set TILT correction in the initialized setting (it is memorized after powering OFF), see Section 6.4.3“Vertical and Horizontal Angle Tilt correction (Tilt ON/OFF)</p>		

4. Angle Measurement

4.1 Measuring Horizontal Angle (Right) and Vertical Angle

Make sure the mode is in Angle measurement

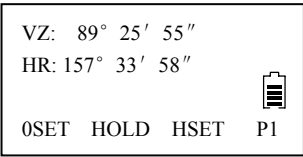
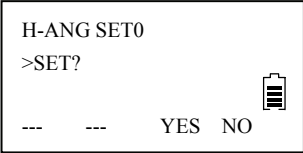
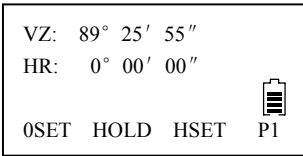
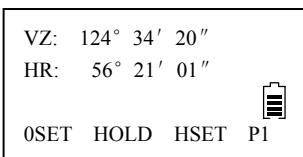
Operating procedure	Operation	Display
①Collimate the 1st target (A).	Collimate A	
②Set horizontal angle of target A at 0°00' 00, press the [F1](OSET) key and press the [F3] (YES) key.	[F1] [F3]	
③Collimate the 2nd target (B).The horizontal angle between B and A and vertical angle of B be displayed.	Collimate B	
		

Reference: How to Collimate

①Point the telescope toward the light back ground. Turn the diopter ring and adjust the diopter so that the cross hairs are clearly observed.

②Aim the target at the cross hair of the sighting collimator. Allow a certain space between the sighting collimator and yourself for collimating.



③Focus the target with the focusing knob.

※If parallax is created between the cross hairs and the target when your eyes move vertically or horizontally, focusing is incorrect or diopter adjustment is poor. This affects precision in measurement.

Eliminate the parallax by carefully focusing and using diopter adjustment.

4.2 Switching Horizontal Angle Right/ Left

Make sure the mode is Angle measurement.

Operating procedure	Operation	Display
<p>① Press the [F4] key twice to get the function on page 3.</p> <p>② Press [F2] (HARL) key. The mode Horizontal angle Right (HR) Switches to (HL) mode.</p> <p>③ Measure at HL mode as HR mode.</p>	<p>[F4] [F4] [F2]</p>	<div style="border: 1px solid black; padding: 5px; margin-bottom: 10px;"> <p>VZ: 89° 25' 55" HR: 168° 36' 18"</p> <p>HABZ HARL CMPS P3 </p> </div> <div style="border: 1px solid black; padding: 5px;"> <p>VZ: 89° 25' 55" HL: 191° 23' 42"</p> <p>HABZ HARL CMPS P3 </p> </div>
<p>● Every time pressing the [F2] (HARL) key, HR/HL mode switches alternately.</p>		

4.3 Set a Horizontal Angle





1) Setting by Holding the Horizontal Angle

Make sure the mode is angle measurement

Operating procedure	Operation	Display
<p>①Set the required horizontal angle, using Horizontal tangent screw</p> <p>②Press[F2](HOLD) key.</p> <p>③Collimate the target.※1)</p> <p>④Press [F3](YES) key to finish holding the horizontal angle. The display turns back to angle measurement mode.</p>	<p>Display angle</p> <p>[F2]</p> <p>[F3]</p>	<div data-bbox="553 304 871 461" style="border: 1px solid black; padding: 5px; margin-bottom: 5px;"> VZ: 89° 25' 55" HR: 191° 23' 42" 0SET HOLD HSET P1 </div> <div data-bbox="553 476 871 633" style="border: 1px solid black; padding: 5px; margin-bottom: 5px;"> H-ANG HOLD HR: 191° 23' 42" >SET? --- --- YES NO </div> <div data-bbox="553 648 871 805" style="border: 1px solid black; padding: 5px;"> VZ: 89° 25' 55" HR: 191° 23' 42" 0SET HOLD HSET P1 </div>
<p>※1) To return to the previous mode, press the [F4] (NO) key.</p>		



2) Setting a horizontal angle by the number key

Make sure the mode is Angle measurement

Operating procedure	Operation	Display
<p>①Collimate the target.</p> <p>②Press[F3](HSET)key.</p> <p>③Input the required horizontal angle by using keys.※1 For example:80°30'50"</p> <p>④Press[F4] to set the horizontal angle.</p>	<p>Collimate</p> <p>[F3]</p> <p>[F1]</p> <p>[80.3050]</p> <p>[F4]</p>	<div data-bbox="619 290 936 446" style="border: 1px solid black; padding: 5px;"> <p>VZ: 89° 25' 55"</p> <p>HR: 168° 36' 18" "</p> <p style="text-align: right;"></p> <p>0SET HOLD HSET P1</p> </div> <div data-bbox="619 483 936 639" style="border: 1px solid black; padding: 5px;"> <p>H-ANG SET</p> <p>HR= 80.3050</p> <p>___ ___ CLR ENT </p> </div> <div data-bbox="619 676 936 832" style="border: 1px solid black; padding: 5px;"> <p>VZ: 89° 25' 55"</p> <p>HR: 80° 30' 50"</p> <p style="text-align: right;"></p> <p>0SET HOLD HSET P1</p> </div>
<p>※1) If input is mistake, press [MENU] () or [F3](CLR) to cancel the input.</p> <p>If the input fault, you have to repeat step from ③.</p>		



4.4 Vertical Angle Grade Mode Switch

Make sure the mode is Angle measurement

Operating procedure	Operation	Display
① Press [F4] key to get the function on page 2.	[F4]	<div style="border: 1px solid black; padding: 5px; margin-bottom: 5px;"> VZ: 67° 38' 15" HR: 168° 36' 19" OSET HOLD HSET P1  </div> <div style="border: 1px solid black; padding: 5px; margin-bottom: 5px;"> TILT REMS V% P2 </div>
② Press [F3](V%) key. ※1)	[F3]	<div style="border: 1px solid black; padding: 5px;"> V: 41.13% HL: 168° 36' 19" TILT REMS V% P2  </div>
※1) Every time pressing the [F3] (V%) key, the display mode switches.		

4.5 Zenith distance/ vertical angle mode switch

Make sure the mode is Angle measurement



Operating procedure	Operation	Display
① Press [F4] (P1) key to get the function on page 3.	[F4]	<div style="border: 1px solid black; padding: 5px; margin-bottom: 5px;"> Vz: 67° 38' 15" HR: 168° 36' 19" OSET HOLD HSET P1  </div> <div style="border: 1px solid black; padding: 5px; margin-bottom: 5px;"> HABZ HARL CMPS P3 </div>
② Press [F3] (CMPS) key. ※1)	[F3]	<div style="border: 1px solid black; padding: 5px;"> VH: 22° 21' 42" HL: 168° 36' 19" HABZ HARL CMPS P3  </div>
※1) Every time press the [F3] key, the display mode switches.		
● At VH mode, vertical angle is 0 when telescope is in horizontal direction.		

4.6 Set Buzzer Sounding for Horizontal Angle 90°

When the horizontal angle falls in the range of $\pm 1^\circ$ of $0^\circ, 90^\circ, 180^\circ$ or 270° , the buzzer sounds. Buzzer stops only when the horizontal angle is adjusted to $0^\circ 00' 00''$, $90^\circ 00' 00''$, $180^\circ 00' 00''$ or $270^\circ 00' 00''$.

This setting is not memorized after powering off.









Make sure the mode is Angle measurement

Operating procedure	Operation	Display
① Press the [F4] key twice to get the function on page 3.	[F4][F4]	<div style="border: 1px solid black; padding: 5px; margin-bottom: 5px;"> Vz: 89° 25' 55" HR: 168° 36' 19"  </div> <div style="border: 1px solid black; padding: 5px; margin-bottom: 5px; display: inline-block;"> 0SET HOLD HEST P1 </div> <div style="border: 1px solid black; padding: 5px; margin-bottom: 5px; display: inline-block;"> TILT REMS V% P2 </div> <div style="border: 1px solid black; padding: 5px; display: inline-block;"> HABZ HARL CMPS P3 </div>
② Press [F1] key. The previously status is shown on the right up corner.	[F1]	<div style="border: 1px solid black; padding: 5px;"> HA Buzzer [OFF]  ON OFF --- ENT </div>
③ Press [F1] (ON) key or [F2] (OFF) key to select the buzzer ON/OFF.	[F1] or [F2]	<div style="border: 1px solid black; padding: 5px;"> HA Buzzer [ON]  ON OFF --- ENT </div>
④ Press [F4] key to set.	[F4]	<div style="border: 1px solid black; padding: 5px;"> VZ: 89° 25' 55" HR: 168° 36' 18" HABZ HARL CMPS P3 </div>

5. Distance Measurement





5.1 Distance Measurement (Slope distance mode)

Make sure the mode is angle measurement.

Operating procedure	Operation	Display
<p>① Press [] key.</p> <p>② Collimate the center of prism.</p> <p>③ Press [F1] key to start measure distance. ※1)</p> <p>④ The measured distance are shown. ※2)~※5)</p>	<p>[]</p> <p>[F1]</p>	<div style="border: 1px solid black; padding: 5px; margin-bottom: 5px;"> VZ: 89° 25' 55" HR: 168° 36' 19"  SD:  DIST MODE S/A P1 </div> <div style="border: 1px solid black; padding: 5px; margin-bottom: 5px;"> VZ: 89° 25' 55" HR: 168° 36' 18"  SD * m  DIST MODE S/A P1 </div> <div style="border: 1px solid black; padding: 5px;"> VZ: 89° 25' 55" HR: 168° 36' 18"  SD: 88.888 m  DIST MODE S/A P1 </div>
<p>※1) When EDM is working, the“- <”mark appears in the display.</p> <p>※2) The measured distance appears with buzzer sounds.</p> <p>※3) The displayed measured distance values depend on the different measurement mode. When the mode is Single measurement, the value is the current measured distance; When the mode is Continuous measurement, the latest display is the average value; When the mode is tracking measurement, the measured distance precision is 0.01m.</p> <p>※4) Press [] key to change distance measurement mode to (HR,HD,VD) modes.</p> <p>※5) If the target is covered, distance can't be measured. Please make sure there is nothing between the target and instrument telescope.</p>		

5.2 Distance Measurement (HD/VD mode)

Make sure the mode is angle measurement

Operating procedure	Operation	Display
<p>① Press [] key twice to into the HD/VD slope distance mode.</p> <p>② Collimate the center of prism.</p> <p>③ Press [F1] key. ※1) The measured distances are shown. ※2)~※4)</p>	<p>[] twice</p> <p>[F1]</p>	<div data-bbox="607 268 933 431" style="border: 1px solid black; padding: 5px;"> <p>HR: 168° 36' 18 "</p> <p>HD: 0.000m </p> <p>VD: 0.000m</p> <p>DIST MODE S/A P1</p> </div> <div data-bbox="607 446 933 609" style="border: 1px solid black; padding: 5px; margin-top: 10px;"> <p>HR: 168° 36' 18 "</p> <p>HD: 88.886m </p> <p>VD: 0.002 m</p> <p>DIST MODE S/A P1</p> </div>
<p>※1) When EDM is working, the“- <”mark appears in the display.</p> <p>※2) The measured distance appears with buzzer sounds.</p> <p>※3) The measured distance display values depend on the different measurement mode. When the mode is Single measurement, the value is the current measured distance; When the mode is Continuous measurement, the latest display is the average value of all; When the mode is tracking measurement, the measured distance precision is 0.01m.</p> <p>※4) Press [] key to change distance measurement mode to (VZ, HR, SD) modes.</p>		

5.3 Distance Offset Measurement

For TS110, Offset measurement has four measuring methods.

1. Angle offset measurement
2. Distance offset measurement
3. Plane offset measurement
4. Column offset measure

5.3.1 Angle offset measurement

This program is used to measure the point where is difficult to set prism. Place the prism at the same horizontal distance from the instrument as that of point A0 to measure.

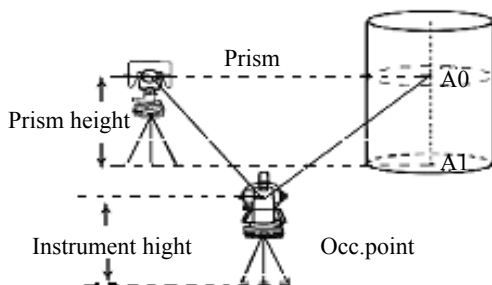



When measuring coordinates of ground point A1: Set the instrument height and prism height.

When measuring coordinates of point A0, set the instrument height only. (Set the prism height to 0).

Make sure the mode is Distance measurement.

Operating procedure	Operation	Display
① Press the [F4] to page 2.	[F4]	<div style="border: 1px solid black; padding: 5px;"> VZ: 89° 25' 55" HR: 168° 36' 19" SD: DIST MODE S/A P1 </div> <div style="border: 1px solid black; padding: 5px; margin-top: 5px;"> OFST S.O m/f/i P2 </div>

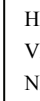
<p>② Press the [F1] (OFST) key.</p> <p>③ Press the [F1](angle offset).</p> <p>④ Collimate the prism.</p> <p>⑤ Press the [F1] (MEAS) key.</p> <p>⑥ Rotate the instrument to collimate the point A0.</p> <p>⑦ Each time press [] key to display HD, VD, SD in sequence.</p> <p>⑧ Each time press [] key to display N, E, Z in sequence.</p> <p>⑨ Press the [F1] (NEXT) key to measure the next point.</p>	<p>[F1]</p> <p>[F1]</p> <p>Collimate prism</p> <p>[F1]</p> <p>Collimate A0</p> <p>[]</p> <p>[]</p>	<div data-bbox="606 140 927 304" style="border: 1px solid black; padding: 5px;"> OFFSET 1/2 F1: ANG. OFFSET F2: DIST. OFFSET F3: PLANE OFFSET </div> <div data-bbox="606 304 927 467" style="border: 1px solid black; padding: 5px;"> ANGLE OFFSET HR: 0° 00' 00" HD m MEAS --- --- --- </div> <div data-bbox="606 467 927 630" style="border: 1px solid black; padding: 5px;"> ANGLE OFFSET HR: 0° 00' 00" HD: 12.345m MEAS--- --- --- </div> <div data-bbox="606 645 927 808" style="border: 1px solid black; padding: 5px;"> OFFSET MEAS HR: 20° 00' 00" VD: 1.345m NEXT--- --- --- </div> <div data-bbox="606 823 927 986" style="border: 1px solid black; padding: 5px;"> OFFSET MEAS HR: 20° 00' 00" N: 501.345m NEXT--- --- --- </div>
<p>1) Press F1:[NEXT] back to step ④</p> <p>2) Press [ESC] back to distance measurement mode</p>		

5.3.2 Distance Offset Measurement

The measurement of an object point apart from a prism is possible by inputting offset horizontal distance of front or back/right or left.

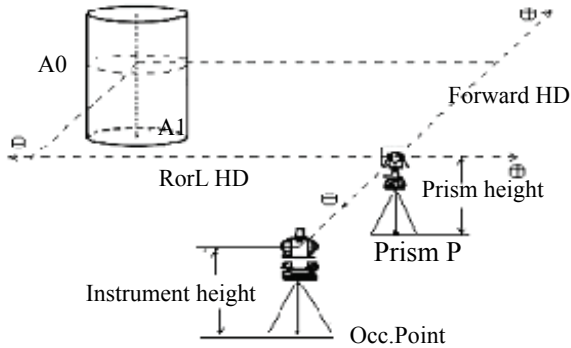

When measuring coordinates of ground point A1: set the instrument height and prism height. When measuring A0: set instrument height only.

Make sure the mode is Distance measurement

Operating procedure	Operation	Display
① Press the [F4] to page 2.	[F4]	<div style="border: 1px solid black; padding: 5px;"> VZ: 89° 25' 55" HR: 168° 36' 19" SD: DIST MODE S/A P1 </div> <div style="border: 1px solid black; padding: 5px; margin-top: 5px;"> OFST S.O m/f/i P2 </div>
② Press the [F1] (OFST) key.	[F1]	<div style="border: 1px solid black; padding: 5px;"> OFFSET 1/2 F1: ANG. OFFSET F2: DIST. OFFSET F3: PLANE OFFSET </div>

<p>③ Press the [F2] key (DIST OFFSET).</p> <p>④ Enter Right or Left distance offset value; press [F4] to confirm.</p> <p>⑤ Enter forward distance offset value; press [F4] to confirm.</p> <p>⑥ Rotate instrument to collimate offset point (Prism P).</p> <p>⑦ Press [F1] key, measuring starts.</p> <p>⑧ Measured data of point A is shown.</p> <p>⑨ Each time press [▲] key to display HD, VD, SD in sequence.</p> <p>⑩ press [↖↗] key to display N, E, Z of point A</p> <p>⑪ Press the [F1] (NEXT) key to measure the next point.</p>	<p>[F2]</p> <p>[F4]</p> <p>[F4]</p> <p>Collimate Offset point</p> <p>[F1]</p> <p>[▲]</p> <p>[↖↗]</p> <p>[F1]</p>	<div style="border: 1px solid black; padding: 5px; margin-bottom: 5px;"> DISTANCE OFFSET INPUT RorL HD oHD=1.000 --- --- CLR ENT </div> <div style="border: 1px solid black; padding: 5px; margin-bottom: 5px;"> DISTANCE OFFSET INPUT FORWARD HD oHD=1.000 --- --- CLR ENT </div> <div style="border: 1px solid black; padding: 5px; margin-bottom: 5px;"> DISTANCE OFFSET HR: 168° 36' 19" HD: 10.000m NEXT --- --- --- </div> <div style="border: 1px solid black; padding: 5px; margin-bottom: 5px;"> DISTANCE OFFSET HR: 168° 36' 19" SD: 11.789m MEAS --- --- --- </div> <div style="border: 1px solid black; padding: 5px; margin-bottom: 5px;"> DISTANCE OFFSET HR: 168° 36' 19" SD: 11.789m MEAS --- --- --- </div> <div style="border: 1px solid black; padding: 5px;"> N: 12.345m E: 23.345m Z: 1.345m MEAS --- --- --- </div>
<p>1) Press F1:[NEXT] back to step ⑥</p> <p>2) Press [ESC] back to step ④</p>		



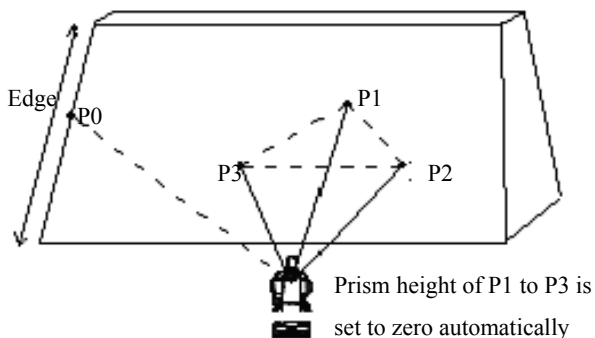

5.3.3 Plane Offset Measurement

Measuring will be taken for the place where direct measuring can not be done, for example distance or coordinate measuring for a edge of a plane.

Three random points (P1, P2, P3) on a plane will be measured at first in the plane offset measurement to determine the measured plane, collimate the measuring point (P0), the instrument calculates and displays coordinate and distance value of cross point between collimation axis and of the plane.



Operating procedure	Operation	Display
① Press the [F4] to page 2.	[F4]	<div style="border: 1px solid black; padding: 5px; margin-bottom: 5px;"> VZ: 89° 25' 55" HR: 168° 36' 19" SD: DIST MODE S/A P1 </div> <div style="border: 1px solid black; padding: 5px;"> OFST S.O m/f/i P2 </div>
② Press the [F1] (OFST) key.	[F1]	<div style="border: 1px solid black; padding: 5px;"> OFFSET 1/2 F1: ANG. OFFSET F2: DIST. OFFSET F3: PLANE OFFSET </div>

Operating procedure	Operation	Display
<p>③ Press the [F3] key (plane offset).</p> <p>④ Collimate point P1, and press the [F1] (MEAS) key to measure. After measuring, the display will show the second point measurement.</p> <p>⑤ Collimate point P2, and press the [F1] (MEAS) key to measure.</p> <p>⑥ Collimate point P3, and press the [F1] (MEAS) key to measure.</p> <p>⑦ Collimate the point P0 on plane edge, the calculated data will be shown.</p> <p>⑧ press  key to display VR, HR, SD of P0</p> <p>⑨ Press  to show N, E, Z of P0.</p> <p>Press [ESC] back to distance measurement mode</p>	<p>[F3]</p> <p>Collimate P1</p> <p>[F1]</p> <p>Collimate P2</p> <p>[F1]</p> <p>Collimate P3</p> <p>[F1]</p> <p>Collimate P0</p> <p></p> <p></p> <p>[ESC]</p>	<div data-bbox="655 182 974 338" style="border: 1px solid black; padding: 5px;"> PLANE N001# SD: m MEAS --- --- --- </div> <div data-bbox="655 350 974 506" style="border: 1px solid black; padding: 5px;"> LANE N002# SD: m MEAS --- --- --- </div> <div data-bbox="655 517 974 673" style="border: 1px solid black; padding: 5px;"> PLANE N003# SD: m MEAS --- --- --- </div> <div data-bbox="655 685 974 841" style="border: 1px solid black; padding: 5px;"> HR : 80° 30' 40" HD : 54.321m VD : 10.000m EXIT </div> <div data-bbox="655 853 974 1009" style="border: 1px solid black; padding: 5px;"> HR : 75° 30' 40" HD : 54.600m VD : -0.487m EXIT </div> <div data-bbox="655 1020 974 1176" style="border: 1px solid black; padding: 5px;"> VR: 90° 30' 40" HR : 75° 30' 40" SD : 56.602m EXIT </div> <div data-bbox="655 1188 974 1344" style="border: 1px solid black; padding: 5px;"> N: 11.237m E: 9.260m Z: 1.234m EXIT </div>

5.3.4 Column Offset Measurement

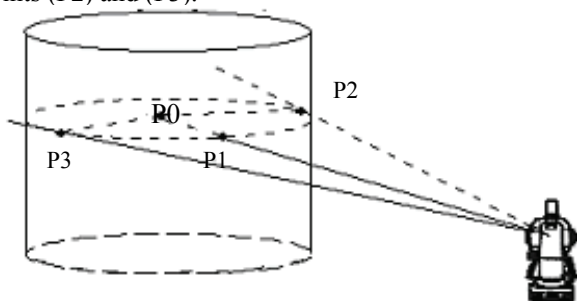

It is possible to measure circumscription point (P1) of column directly, the distance to the center of the column (P0), coordinate and direction angle can be calculated by measuring circumscription points (P2) and (P3)

The direction angle of the column center is average of circumscription points (P2) and (P3).



Make sure the mode is Distance measurement

Operating procedure	Operation	Display
① Press the [F4] to page 2.	[F4]	<div style="border: 1px solid black; padding: 5px; margin-bottom: 5px;"> VZ: 89° 25' 55" HR: 168° 36' 19" SD: DIST MODE S/A P1 </div> <div style="border: 1px solid black; padding: 5px; margin-bottom: 5px;"> OFST S.O m/f/i P2 </div>
② Press the [F1] (OFST) key.	[F1]	<div style="border: 1px solid black; padding: 5px; margin-bottom: 5px;"> OFFSET 1/2 F1: ANG. OFFSET F2: DIST. OFFSET F3: PLANE OFFSET </div>
③ Press ▼ key to display next page	▼	<div style="border: 1px solid black; padding: 5px;"> OFFSET 2/2 F1: COLUMN OFFSET </div>

<p>Press the [F1] (column offset) key.</p> <p>④Collimate the center of column P1, and press the [F1] (MEAS) key to measure N times.</p> <p>⑤Collimate the left side of the column (P2) and press the [F4] (SET) key.</p> <p>⑥Collimate the right side of the column (P3) and press the [F4] (SET) key.</p> <p>⑦The distance between the instrument and center of the column (P0) will be calculated and shown.</p> <p>⑧Each time press [] key to display HD, VD, SD in sequence.</p> <p>⑨Press [] to show N, E, Z of column center.</p>	<p>Collimate P1 [F1]</p> <p>Collimate P2 [F4]</p> <p>Collimate P3 [F4]</p> <p></p> <p>[F3]</p>	<div data-bbox="640 140 958 296" style="border: 1px solid black; padding: 5px;"> <p>COLUMN OFFSET Center HD: m MEAS --- --- ---</p> </div> <div data-bbox="640 304 958 460" style="border: 1px solid black; padding: 5px;"> <p>COLUMN OFFSET Center HD* 1.234m < Measuring ></p> </div> <div data-bbox="640 467 958 623" style="border: 1px solid black; padding: 5px;"> <p>COLUMN OFFSET Left HR: 12° 34' 56" --- --- --- SET</p> </div> <div data-bbox="640 630 958 786" style="border: 1px solid black; padding: 5px;"> <p>COLUMN OFFSET Right HR: 12° 34' 56" --- --- --- SET</p> </div> <div data-bbox="640 793 958 949" style="border: 1px solid black; padding: 5px;"> <p>COLUMN OFFSET HR: 12° 34' 56" HD: 1.234m NEXT --- --- ---</p> </div> <div data-bbox="640 957 958 1113" style="border: 1px solid black; padding: 5px;"> <p>COLUMN OFFSET HR: 12° 34' 56" VD: 0.000m NEXT --- --- ---</p> </div>
---	---	--





5.4 Stake out (S.O)

The difference between the measured distance and the input stake out distance is displayed.

Displayed value=Measured distances-Stake out distance

In stake out operation, you can select either horizontal distance (HD), relative elevation(VD)or slope distance (SD).

Make sure the mode is Distance measurement

Operating procedure	Operation	Display
①Press [F4] (P1) key from distance measuring mode to get the function on page 2.	[F4]	VZ: 89° 25' 55" HR: 168° 36' 19" SD: DIST MODE S/A P1
②Press [F2] (S.O) key.	[F2]	OFST S.O m/f/i P2
③Press[F1](HD) key. ※1)	[F1]	SET OUT HD: 0.000m 
④Enter the distance for stake out and press [F4] key. Collimate the prism.	[F4]	HD VD SD ---
⑤Press [F4] key to return HD mode page 1, press [F1] starts measuring. +value means move prism toward the instrument. -value means move prism backward the instrument.	[F4] [F1]	SET OUT HD: 10.000m  ---- CLR ENT
		HR: 168° 36' 18"  dHD: -12.410m VD: 0.000m OFST S.O. m/f/i P2
		HR: 168° 36' 18"  dHD: -12.410m VD: 0.000m DIST REC --- P1

※1) At step ④, if we set the stake out distance as 0, the program will return to normal distance measurement mode.

5.5 Set distance measurement mode

There are two modes can be selected: F1: FINE, F2: TRK

For F1: FINE mode, press [DIST] key to measure distance according to the set times, the first measuring time is about 3s, minimum reading is 1mm.

For F2: TRK mode, press [DIST] key to measure distance continuously until press [ESC] key, the first measuring time is about 2s, minimum reading is 10mm.

Make sure the mode is Distance measurement

Operating procedure	Operation	Display
① Press [F2](MODE) key. Current setting will display at the bottom corner. “T” means current setting is tracking mode. “F” means current setting is fine mode. ② Press [F1](FINE), the current setting will change to fine mode, and back to normal measurement screen.	[F2]	VZ: 89° 25' 55" HR: 168° 36' 19" SD: DIST MODE S/A P1
	[F1]	VZ: 89° 25' 55" HR: 168° 36' 19" SD: FINE TRK --- T
	[ESC]	VZ: 89° 25' 55" HR: 168° 36' 19" SD: DIST MODE S/A P1



5.6 Set distance unit

Make sure the mode is Distance measurement

Operating procedure	Operation	Display
<p>① Press[F4](P1) key from distance measuring mode to get the function on page 2.</p> <p>② Every time press [F3](m/f/i), the current unit will change among m, ft, inch in sequence.</p>	[F4]	<div style="border: 1px solid black; padding: 5px;"> VZ: 89° 25' 55" HR: 168° 36' 19" SD: m DIST MODE S/A P1 </div>
	[F3]	<div style="border: 1px solid black; padding: 5px;"> OFST S.O m/f/i P2 </div> <div style="border: 1px solid black; padding: 5px; margin-top: 5px;"> VZ: 89° 25' 55" HR: 168° 36' 19" SD: f OSET S.O. m/f/I P2 </div>

5.7 Setting of the Atmospheric Correction

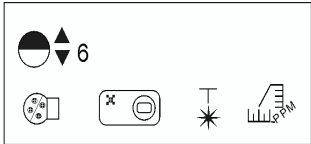
These series Total Station setting the atmospheric correction value by input directly the temperature and pressure value.

Operating procedure	Operation	Display								
① Press [★]key.	[★]									
② Press [F4]() key.	[F4]	<table border="1"> <tr> <td>EDM SET</td> <td>F1:</td> </tr> <tr> <td>PSM-30.0</td> <td>PPM -1.9</td> </tr> <tr> <td>Signal:</td> <td>[]</td> </tr> <tr> <td>PSM</td> <td>PPM T-P TIMS</td> </tr> </table>	EDM SET	F1:	PSM-30.0	PPM -1.9	Signal:	[]	PSM	PPM T-P TIMS
EDM SET	F1:									
PSM-30.0	PPM -1.9									
Signal:	[]									
PSM	PPM T-P TIMS									
③ Press [F3] key.	[F3]	<table border="1"> <tr> <td>PPM:000</td> </tr> <tr> <td>TEMP = 18.0_ ° C</td> </tr> <tr> <td>PRES : 1020.0 hPa</td> </tr> <tr> <td>--- --- CLR ENT</td> </tr> </table>	PPM:000	TEMP = 18.0_ ° C	PRES : 1020.0 hPa	--- --- CLR ENT				
PPM:000										
TEMP = 18.0_ ° C										
PRES : 1020.0 hPa										
--- --- CLR ENT										
④ Input the prism constant correction value.										
⑤ Press[F4]key to save the setting.	[F4]	<table border="1"> <tr> <td>PPM:000</td> </tr> <tr> <td>TEMP = 25_ ° C</td> </tr> <tr> <td>PRES : 1020.0 hPa</td> </tr> <tr> <td>--- --- CLR ENT</td> </tr> </table>	PPM:000	TEMP = 25_ ° C	PRES : 1020.0 hPa	--- --- CLR ENT				
PPM:000										
TEMP = 25_ ° C										
PRES : 1020.0 hPa										
--- --- CLR ENT										

The atmospheric correction is little effect on distance measurement. But if the input Temp. value and pressure value is big different from the measuring value, the distance different should be more than 0.001m.

Input range: $-40.0^{\circ}\text{C} < \text{Temperature} < +60.0^{\circ}\text{C}$



$-40.0^{\circ}\text{F} < \text{Temperature} < +140.0^{\circ}\text{F}$

Input range: $+500.0\text{hpa} < \text{Pressure} < +1500.0\text{hpa}$

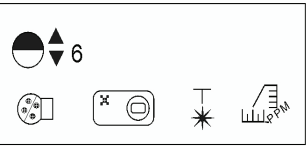

+500.0mbar<Pressure< +1500.0mbar
 +375.0mmHg<Pressure< +1125.0mmHg
 +14.8inhg<Pressure< +44.3inhg
 +7.3psi<Pressure< +21.8hpa

5.8 Returned signal Checking

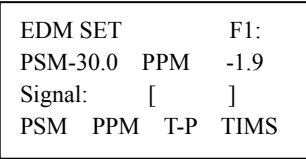
Check to make sure that sufficient reflected light is returned by the reflective prism sighted by the telescope.

Operating procedure	Operation	Display
① Press [★]key.	[★]	
② Press [F4]  key.	[F4]	
③ The intensity of current returned signal is shown on the third line..		
④ Press[ESC]key to return the previous mode.	[ESC]	

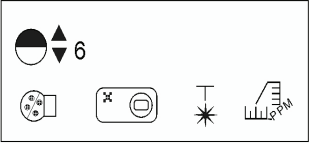
5.9 Setting distance measurement times (Factory setting is “3”)

Operating procedure	Operation	Display								
③ Press [★]key.	[★]									
④ Press [F4]  key.	[F4]	<table border="1" data-bbox="567 461 891 624"> <tr> <td>EDM SET</td> <td>F1:</td> </tr> <tr> <td>PSM-30.0 PPM</td> <td>-1.9</td> </tr> <tr> <td>Signal: []</td> <td></td> </tr> <tr> <td>PSM PPM T-P</td> <td>TIMS</td> </tr> </table>	EDM SET	F1:	PSM-30.0 PPM	-1.9	Signal: []		PSM PPM T-P	TIMS
EDM SET	F1:									
PSM-30.0 PPM	-1.9									
Signal: []										
PSM PPM T-P	TIMS									
⑤ Press [F4] key.	[F4]	<table border="1" data-bbox="567 639 891 802"> <tr> <td colspan="2">DIST TIMES SET</td> </tr> <tr> <td colspan="2">TIMES=3_</td> </tr> <tr> <td>---</td> <td>CLR ENT</td> </tr> </table>	DIST TIMES SET		TIMES=3_		---	CLR ENT		
DIST TIMES SET										
TIMES=3_										
---	CLR ENT									
④ Input the distance measurement times. ⑤ Press [F4]key to save the setting.	[F4]	<table border="1" data-bbox="567 817 891 980"> <tr> <td colspan="2">DIST TIMES SET</td> </tr> <tr> <td colspan="2">TIMES=5_</td> </tr> <tr> <td>---</td> <td>CLR ENT</td> </tr> </table>	DIST TIMES SET		TIMES=5_		---	CLR ENT		
DIST TIMES SET										
TIMES=5_										
---	CLR ENT									

NOTE: It is not possible to set the times as “0”. The appropriate time is “3”, which is better for saving power and high accuracy.

6. Coordinate Measurement

Set the coordinates of the instrument (occupied point) and backsight point, the instrument can measure and displays the unknown point (prism point) coordinates

Press [\swarrow] key to switch to coordinate measurement mode.

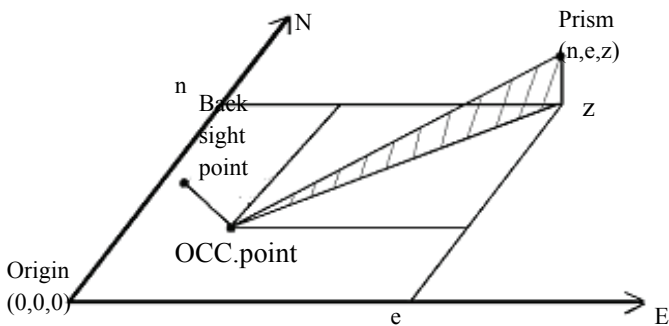



6.1 Setting Coordinate of Occupied point

1) Coordinate data input by keyboard directly

Operating procedure	Operation	Display										
① Press [] key.	[]	<table border="1"> <tr><td>N :</td><td>0.000m</td></tr> <tr><td>E :</td><td>0.000m</td></tr> <tr><td>Z :</td><td>0.000m</td></tr> <tr><td>DIST MODE</td><td>S/A P1</td></tr> </table>	N :	0.000m	E :	0.000m	Z :	0.000m	DIST MODE	S/A P1		
N :	0.000m											
E :	0.000m											
Z :	0.000m											
DIST MODE	S/A P1											
② Press [F4] key to display the function page2.	[F4]	<table border="1"> <tr><td>RFHT</td><td>IHT</td><td>INCO</td><td>P2</td></tr> </table>	RFHT	IHT	INCO	P2						
RFHT	IHT	INCO	P2									
③ Press [F3] (INCO) key. ※1)	[F3]	<table border="1"> <tr><td>N = 0.000_</td><td>m</td></tr> <tr><td>E :</td><td>0.000m</td></tr> <tr><td>Z :</td><td>0.000m</td></tr> <tr><td>---</td><td>---</td><td>CLR</td><td>ENT</td></tr> </table>	N = 0.000_	m	E :	0.000m	Z :	0.000m	---	---	CLR	ENT
N = 0.000_	m											
E :	0.000m											
Z :	0.000m											
---	---	CLR	ENT									
④ Enter the coordinate. ※2)	Enter											
⑤ After NEZ coordinate is entered, press [F4] to confirm, the instrument returns coordinate measurement menu on page 2.	NEZ data [F4]	<table border="1"> <tr><td>N :</td><td>123.456m</td></tr> <tr><td>E :</td><td>-987.015m</td></tr> <tr><td>Z :</td><td>0.803 m</td></tr> <tr><td>---</td><td>---</td><td>CLR</td><td>ENT</td></tr> </table>	N :	123.456m	E :	-987.015m	Z :	0.803 m	---	---	CLR	ENT
N :	123.456m											
E :	-987.015m											
Z :	0.803 m											
---	---	CLR	ENT									
<p>※1) “=” means the current entering item, the item can be entered right now. After enter and press [F4] key, the “=” moves to the next line. If this item need not to enter, press [F4] key to move “=” directly.</p> <p>※2) Input range: -99999999.9990m< N,E,Z< +99999999.9990m Input range: -99999999.9990ft< N,E,Z< +99999999.9990ft Input range: -99999999.11.7ft+in< N,E,Z< +99999999.11.7ft+in</p>												

6.2 Setting of instrument height

After power off, the instrument height can be saved.

Operating procedure	Operation	Display
<p>① Press  key.</p> <p>② Press [F4] key to display the function page2.</p> <p>③ Press [F2] (IHT) key.</p> <p>④ Enter the instrument height, press F4 to confirm, the instrument returns coordinate measurement menu on page 2.</p> <p>※1)</p>	<p></p> <p>[F4]</p> <p>[F2]</p> <p>Enter</p> <p>Inst.H</p> <p>[F4]</p>	<div data-bbox="536 259 857 408" style="border: 1px solid black; padding: 5px;"> <p>N : 123.456m E : -987.015m Z : 0.803 m</p> </div> <div data-bbox="536 408 857 471" style="border: 1px solid black; padding: 5px;"> <p>DIST MODE S/A P1</p> <p>RFHT IHT INCO P2</p> </div> <div data-bbox="536 471 857 635" style="border: 1px solid black; padding: 5px;"> <p>INSTRUMETN HEIGHT INPUT Ins.Hi=1.174_ m --- --- CLR ENT</p> </div> <div data-bbox="536 635 857 805" style="border: 1px solid black; padding: 5px;"> <p>N : 123.456m E : -987.015m Z : 0.803 m</p> <p>RFHT IHT INCO P2</p> </div>
<p>※1) Input range: -999.9990m< Inst.H< +999.9990m Input range: -999.9990ft< Inst.H< +999.9990ft Input range: -999.11.7 ft+in< Inst.H< +999.11.7 ft+in</p>		

6.3 Setting of target height

After power off, the target height can be saved.

Operating procedure	Operation	Display										
① Press [↖.]key .	[↖.]	<table border="1"> <tr><td>N :</td><td>123.456m</td></tr> <tr><td>E :</td><td>-987.015m</td></tr> <tr><td>Z :</td><td>0.803 m</td></tr> <tr><td colspan="2">DIST MODE S/A P1</td></tr> <tr><td colspan="2">RFHT IHT INCO P2</td></tr> </table>	N :	123.456m	E :	-987.015m	Z :	0.803 m	DIST MODE S/A P1		RFHT IHT INCO P2	
N :	123.456m											
E :	-987.015m											
Z :	0.803 m											
DIST MODE S/A P1												
RFHT IHT INCO P2												
② Press[F4]key to display the function page2.	[F4]	<table border="1"> <tr><td colspan="2">REF HT INPUT</td></tr> <tr><td>Ref.Hr=2.500_</td><td>m</td></tr> <tr><td>---</td><td>--- CLR ENT</td></tr> </table>	REF HT INPUT		Ref.Hr=2.500_	m	---	--- CLR ENT				
REF HT INPUT												
Ref.Hr=2.500_	m											
---	--- CLR ENT											
③ Press[F1](RFHT)key.	[F1]											
④ Enter the target height, press F4 to confirm, the instrument returns coordinate measurement menu on page 2..	Enter Targ.H											
※1)	[F4]	<table border="1"> <tr><td>N :</td><td>123.456m</td></tr> <tr><td>E :</td><td>-987.015m</td></tr> <tr><td>Z :</td><td>0.803 m</td></tr> <tr><td colspan="2">RFHT IHT INCO P2</td></tr> </table>	N :	123.456m	E :	-987.015m	Z :	0.803 m	RFHT IHT INCO P2			
N :	123.456m											
E :	-987.015m											
Z :	0.803 m											
RFHT IHT INCO P2												
※1) Input range: -999.9990m< Ref.H< +999.9990m Input range: -999.9990ft< Ref.H< +999.9990ft Input range: -999.11.7 ft+in< Inst.H< +999.11.7 ft+in												



6.4 Setting coordinate of backsight point

Direct key input of coordinate data

Operating procedure	Operation	Display
<p>① Displaying the coordinate measurement mode on page 3.</p>		<div style="border: 1px solid black; padding: 5px; margin-bottom: 5px;"> N : 123.456m E : -987.015m Z : 0.803 m  </div> <div style="border: 1px solid black; padding: 5px; margin-bottom: 5px;"> DIST MODE S/A P1 </div> <div style="border: 1px solid black; padding: 5px; margin-bottom: 5px;"> RFHT IHT INCO P2 </div> <div style="border: 1px solid black; padding: 5px;"> OFST BS m/f/i P3 </div>
<p>② Press [F2] key to get the function of setting backsight point.</p>	[F2]	<div style="border: 1px solid black; padding: 5px;"> N= 0.000_m E : 0.000m Z: 0.000m --- --- CLR ENT </div>
<p>③ Enter the coordinate.</p>	Input	<div style="border: 1px solid black; padding: 5px;"> N= <u>0</u>.000m E : 0.000m Z: 0.000m --- --- CLR ENT </div>
<p>④ After NEZ coordinate is entered; press [F4] to confirm.</p>	N,E,Z [F4]	<div style="border: 1px solid black; padding: 5px;"> BACKSIGHT HR: 12° 34' 56" </div>
<p>⑤ Collimate backsight point prism center, press [F3] (YES) key. The azimuth angle is set, and instrument returns coordinate measurement menu on page 3.</p>	AIM [F3]	<div style="border: 1px solid black; padding: 5px; margin-bottom: 5px;"> >Sight? YES NO </div> <div style="border: 1px solid black; padding: 5px;"> N : 123.456m E : -987.015m Z : 0.803 m OFST BS m/f/i P3 </div>

6.5 Measuring point coordinate

After setting the coordinate of instrument and backsight, instrument height and target height, collimate the point to measure its coordinate.

Operating procedure	Operation	Display
<p>①In coordinate measurement mode function page1.</p> <p>②Collimate prism, press [F1] key, the instrument begins to measure distance and then give the final result.</p>	<p>Collimate [F1]</p>	<div data-bbox="606 342 927 501" style="border: 1px solid black; padding: 5px;"> <p>N : 123.456m E : 987.654m Z : 1.000m  DIST MODE S/A P1</p> </div> <div data-bbox="606 516 927 675" style="border: 1px solid black; padding: 5px;"> <p>N:*[3] -< m E : 1020.821m Z : -2.345m  DIST MODE S/A P1</p> </div> <div data-bbox="606 690 927 848" style="border: 1px solid black; padding: 5px;"> <p>N : 135.400m E : 1020.821m Z : -2.345m  DIST REC --- P1</p> </div>

7. Data collection

These series total station is able to store the measured data into the internal memory. The internal memory is shared by the measured data files and the coordinate data files.

7.1 Data collection menu operation

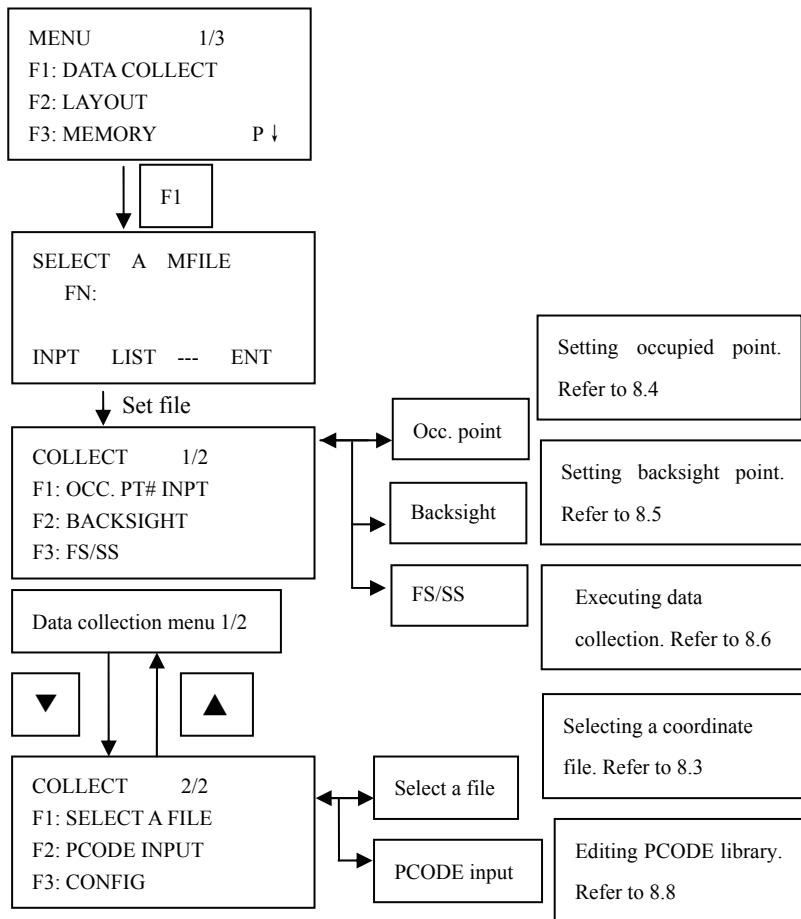

7.2 Selecting a file for data collection

Select a file before beginning data collection. The measured data could be stored into the selected file.

Operating procedure	Operation	Display
① Press [MENU] key enter the menu display.	[MENU]	<pre>MENU 1/3 F1:DATA COLLECT F2:LAYOUT F3:MEMORY MGR P ↓</pre>
② Press [F1] key enter data collection.	[F1]	<pre>SELECT A MFILE FN: INPT LIST --- ENT</pre>
③ Press [F2] key to display the file list. ※1)	[F2]	<pre>> *1 /C0003 1SV /C0000 TOP LAST SRCH ENT</pre>
④ Scroll file list by pressing [▲] or [▼] key and select one file to use. ※2)	[▲] [▼]	<pre>1 /C0003 >*1SV /C0000 S /C0000 TOP LAST SRCH ENT</pre>
⑤ Press [F4] key. The file will be set.	[F4]	<pre>COLLECT 1/2 F1: OCC. PT# INPT F2: BACKSIGHT F3: FS/SS</pre>
<p>※1) If you want to input file name directly, press[F1] key and enter a file name.</p> <p>※2) When a file has been selected already, “*” mark is indicated on left of current file name.</p> <p>● It is possible to select a file from DATA COLLECT 2/2, menu in the same way.</p>		

7.3 Selecting a coordinate file for data collection

When coordinate data in a coordinate data file are used for occupied point or backsight point, select a coordinate file beforehand.

Operating procedure	Operation	Display
① Enter the page 2 of data collection menu.		<pre>COLLECT 2/2 F1 : SELECT A FILE F2 :PCODE INPUT F3 :CONFIG P ↓</pre>
② Press [F1 key.	[F1]	<pre>SELECT A FILE F1 : MEAS.FILE F2: COORD.FILE</pre>
③ Press [F2] key.	[F2]	<pre>SELECT A FILE FN:</pre>
④ Press [F2] key to display the list of file.	[F2]	<pre>INPT LIST --- ENT</pre>
⑤ Scroll file list by pressing [▲] or [▼] key and select a file to use.	[▼]	<pre>> @FOIF_01/0012 FOIF_02/0102 FOIF_03/0008 TOP LAST SRCH ENT</pre>
⑥ Press [F4] key. The file will be set.	[F4]	<pre>FOIF_01/0012 > @FOIF_02/0102 FOIF_03/0008 TOP LAST SRCH ENT</pre>
		<pre>COLLECT 2/2 F1 :SELECT A FILE F2 :PCODE INPUT F3 :CONFIG</pre>

7.4 Occupied Point Setting

1) Setting the coordinate data from the internal memory.

Operating procedure	Operation	Display
① Make sure the displaying is Data Collect menu.		<pre> COLLECT 1/2 F1 : OCC. PT# INPUT F2 : BACKSIGHT F3 : FS/SS P ↓ </pre>
② Press [F1] (OCC. PT# INPUT) key, displays PT# input menu.	[F1]	<pre> PT# > PCODE : Ins.Hi : 1.000 m INPT SRCH REC STN </pre>
③ Press [F4] key.	[F4]	<pre> OCC. PT PT#: INPT LIST NEZ ENT </pre>
④ Press [F2] key to display the list of PT#. ※1)	[F2]	<pre> [FOIF] > F001 F002 VIEW SRCH --- ENT </pre>
⑤ Scroll PT# list by pressing [▲] or [▼] key and select PT#. Press [F4] key. ※2) ※3)	[▲]or [▼] [F4]	<pre> N 5.620m E 4.210m Z 1.250m >OK? YES NO </pre>
⑥ Press [F3] to select YES.	[F3]	<pre> PT# >F001 PCODE : Ins.Hi : 1.000 m INPT SRCH REC STN </pre>

※1) If you want to input PT# directly, press [F1]key and enter PT#.

※2) The coordinate data can be viewed by press [F1](VIEW)key.

※3) The coordinate data can be searched by press [F2](SRCH) key.

※4) If the input number is 1-50, it should be ID of PCODE in library.

2) Input the instrument point coordinates by hand

Operating procedure	Operation	Display
① Make sure the displaying is Data Collect menu.		<pre>COLLECT 1/2 F1: OCC. PT# INPT F2: BACKSIGHT F3: FS/SS</pre>
② Press [F1] (OCC. PT# INPUT) key, displays PT# input menu.	[F1]	<pre>PT# > PCODE: Ins.Hi : 1.000 m INPT SRCH REC STN</pre>
③ Press [F4] key.	[F4]	<pre>OCC. PT PT#: INPT LIST NEZ ENT</pre>
④ Press [F3] (NEZ) to enter coordinate input menu.	[F3]	<pre>N: 123.456 m E: 987.654 m Z= -1.608_ m --- --- CLR ENT</pre>
⑤ Press [F1] key and enter coordinate values.	[F1]	
※ 1)		
⑥ Press [F3] (YES) to record the input coordinate to memory.	[F3]	<pre>N: 123.456 m E: 987.650 m Z: -1.608 m >REC ? [YES] [NO]</pre>
⑦ After enter the PT# and then press [F4] to confirm	[F4]	<pre>INPUT COORD PT# : 5 INPT LIST --- ENT</pre>
		<pre>PT# >5 PCODE : Ins.Hi : 1.000 m INPT SRCH REC STN</pre>

7.5 Backsight Point

1) Setting the coordinate data from the internal memory

Make sure the mode is Data Collect.

Operating procedure	Operation	Display
① Make sure the displaying is Data Collect menu.		COLLECT 1/2 F1 :OCC.PT# INPUT F2 :BACKSIGHT F3 :FS/SS P ↓
② Press [F2] (BACK SIGHT) key.	[F2]	BS# > PCODE: Ref.Hr: 0.000m INPT 0SET MEAS BS
③ Press [F4] (BS) key. ※1)	[F4]	BACK SIGHT PT# : INPT LIST NEAZ ENT
④ Press [F1] key and enter PT#. ※2)	[F1] Input PT#	BACK SIGHT PT# =F002_
⑤ Press [F4] key, the coordinate will display	[F4]	ALPH SPC CLR ENT
⑥ Press [F4] (YES) key.	[F4]	N: 22.000m E: 123.210m Z: 100.000m >OK? [NO] [YES]
⑦ Collimate backsight point, press [F3] (YES) key. ※3) The display returns to BS menu, press [ESC] return to Data Collect main menu.	[F3]	BACKSIAHT HL :179° 59' 07" >Sight? dHD YES NO
		BS# >F002 PCODE : Ref.Hr: 0.000m INPT BS MEAS 0SET

- ※1) The coordinate data can be searched by press [F2](LIST)key.
- ※2) Press [F3] key, backsight setting mode will be switched among NEAZ/AZ/PT#.
- ※3) Press [F1](dHD) to measure the horizontal difference between calculated Backsight and true backsight.

2) Setting the direction angle

Make sure the mode is Data Collect.

Operating procedure	Operation	Display
① Make sure the displaying is Data Collect menu.	[F2]	<pre> COLLECT 1/2 F1 :OCC.PT# INPUT F2 :BACKSIGHT F3 :FS/SS P ↓ </pre>
② Press [F2](BACK SIGHT) key.	[F3]	<pre> BS# > PCODE: Ref.Hr: 0.000m INPT 0SET MEAS BS </pre>
③ Press [F4](BS) key. ※1)	[F3]	<pre> BACK SIGHT PT# : INPT LIST NEAZ ENT </pre>
④ Press [F3] twice to enter AZ inputting menu.	[F3]	<pre> BACK SIGHT HR: INPT ---- PT# ENT </pre>
⑤ Press [F1] key, input the direction angle. 186°56'00" Press [F4] key.	[F1] [186.5600] [F4]	<pre> BACK SIGHT HR=186.5600_ --- --- CLR ENT </pre>

<p>⑥ Collimate backsight point, press [F3]key. The display returns to BS menu.</p>	<p>Collimate backsight point [F3]</p>	<div style="border: 1px solid black; padding: 5px;"> <p>BACKSIAHT HL :186° 56' 00" >Sight? YES NO</p> </div>
--	---	---

7.6 Operational Procedure of “Data Collect”

Make sure the mode is Data Collect.

Operating procedure	Operation	Display
<p>①Press [F3] (FS/SS) key.</p> <p>②Press [F1] key and input PT#, PCODE, Ref.Hr. Press [F3](MEAS)key. ※1)</p> <p>③There are four modes can be selected, press [F2](HD) key, HD/VD data will be measured.※2) ※3)</p> <p>④Press [F3](YES) to record the measured data to memory. ※4)</p> <p>④The display changes to previous menu, and it is ready to measuring next point. PT# is automatically incremented.</p>	<p>[F3]</p> <p>[F3]</p> <p>[F2]</p> <p>[F3]</p> <p>[F4]</p>	<div style="border: 1px solid black; padding: 5px;"> <p>PT# > PCODE : 0 Ref.Hr : 0.000m INPT SRCH MEAS ALL</p> </div> <div style="border: 1px solid black; padding: 5px;"> <p>PT# :F021 PCODE : FOIF Ref.Hr : 1.000m VH HD NEZ OFST</p> </div> <div style="border: 1px solid black; padding: 5px;"> <p>HR : 0° 00' 00" HD: m VD -< <Measuring></p> </div> <div style="border: 1px solid black; padding: 5px;"> <p>HA : 58° 14' 22" HD: 56.461 m VD: 5.625 m >OK [YES] [NO]</p> </div> <div style="border: 1px solid black; padding: 5px;"> <p>PT# :F022 ID :FOIF Ref.Hr : 1.000m INPT SRCH MEAS ALL</p> </div>

Press [F4] (ALL) key to measure next point in the same measuring mode(HD) with previous point.※5) ※6)

HR : 180° 05' 18"
HD: m
VD -<
<Measuring>

※1) When the mark > is located PCODE, PCODE can be input directly, or recall by inputting a register number linked with PCODE Library. To show the list of PCODE library, press the [F2] (SRCH)

※2) VH means the measured data is in angle format, the HD/SD means the data is in angle and distance format, NEZ means the data is in coordinate format.

※3) In DATA COLLECT/CONFIG/F1:HD/SD menu, if current setting is SD, here SD is displayed to be set

※4) In DATA COLLECT/CONFIG/F3:DATA CONFIRM menu, if current setting is NO, this asking screen will not display and the measured data will be recorded automatically.

※5) Press F4 (ALL) to measure next point, the PT# will increase one automatically, PCODE and the Ref.Hr, and distance measurement mode will not change, according to your need to edit every item before selecting ALL.

※6) While executing the DATA COLLECT mode, you can search the recorded data.

● While executing the DATA COLLECT mode, press [F2](SRCH) key.

● Select one of three search methods by pressing [F1] to [F3] key
The operation is same as the "SEARCH" in the MEMORY MANAGER mode.

PT# :F022
ID :FOIF
Ref.Hr : 1.000m
INPT SRCH MEAS ALL

MEAS.DATA SEARCH
F1:FIRST DATA
F2:LAST DATA
F3:PT# DATA

7.7 Setting PCODE for measured point

7.7.1 Entering PCODE / ID using PCODE Library

While executing the DATA COLLECT mode, you can enter PCODE /ID from PCODE Library.

Operating procedure	Operation	Display
<p>① Move the arrow to the PCODE</p> <p>② Press [F1] to enter a register number linked with PCODE library and press the [F4](ENT) key. (Example) Register number, 12 = FOIF</p>	<p>[F1] Input ID of PCODE [F4]</p>	<div data-bbox="617 327 936 483" style="border: 1px solid black; padding: 5px;"> PT# :F023 PCODE > Ref.Hr : 0.000m INPT SRCH MEAS ALL </div> <div data-bbox="617 498 936 654" style="border: 1px solid black; padding: 5px;"> PT# :F023 PCODE =12_ Ref.Hr : 0.000m NUM SPC CLR ENT </div> <div data-bbox="617 691 936 847" style="border: 1px solid black; padding: 5px;"> PT# :F023 PCODE :FOIF Ref.Hr > 0.000m INPT SRCH MEAS ALL </div>

7.7.2 Entering PCODE / ID from the list of PCODE

You can also enter PCODE / ID from the list of PCODE.

Operating procedure	Operation	Display
<p>① Move the arrow to the PCODE, press [F2](SRCH)</p> <p>② By pressing the following keys, the register number will increase or decrease. [▲]or[▼]:Increasing or decreasing one by one [◀] or ▶]: By ten increasing or Decreasing. *1) Press [F4] (ENT) to confirm.</p>	<p>[F2]</p> <p>[F4]</p>	<div style="border: 1px solid black; padding: 5px; margin-bottom: 5px;"> PT# :F023 PCODE > Ref.Hr : 0.000m INPT SRCH MEAS ALL </div> <div style="border: 1px solid black; padding: 5px; margin-bottom: 5px;"> >001:TREE 002:SYG EDIT --- CLR ENT </div> <div style="border: 1px solid black; padding: 5px; margin-bottom: 5px;"> 011:DKIID >012:FOIF 013:IOOF EDIT --- CLR ENT </div> <div style="border: 1px solid black; padding: 5px;"> PT# :F023 PCODE >FOIF Ref.Hr > 0.000m INPT SRCH MEAS ALL </div>
<p>※1) To edit the PCODE library, press the [F1](EDIT) key. To delete the PCODE registered with shown an arrow, press the [F3] (CLR) key. PCODE can be edited in DATA COLLECT menu 2/2 or MEMORY MANAGER menu 2/3.</p>		

7.8 Data Collect Offset Measurement mode

For these series total station, Offset measurement has four measuring methods:

1. Angle offset measurement
2. Distance offset measurement
3. Plane offset measurement
4. Column offset measurement

7.8.1 Angle offset measurement

This program is used to measure the point where is difficult to set prism. Place the prism at the same horizontal distance from the instrument as that of point A0 to measure.

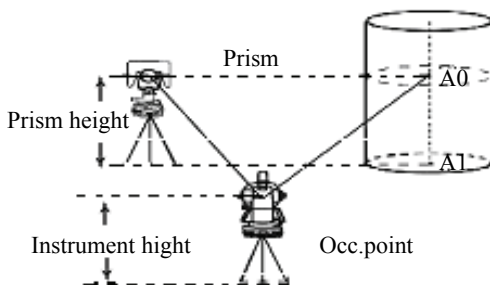

When measuring coordinates of ground point A1: Set the instrument height and prism height.

When measuring coordinates of point A0: set the instrument height only. (Set the prism height to 0). Make sure the mode is Data Collect.

Operating procedure	Operation	Display
① Press the [F3] (MEAS) key.	[F3]	<pre> PT# > PCODE: Ref.Hr: 0.000m INPT SRCH MEAS ALL </pre> <hr/> <pre> VH HD NEZ OFST </pre>

<p>② Press the [F4] (OFST) key.</p> <p>③ Press the [F1] (angle offset).</p> <p>④ Collimate the prism, press [F3] to measure distance.</p> <p>⑤ Collimate point A0 using the horizontal motion clamp and horizontal tangent screw.</p> <p>※1) Press [F3] (YES) to confirm, the measured data of A0 will be recorded.</p>	<p>[F4]</p> <p>[F1]</p> <p>Collimate prism [F3]</p> <p>Collimate A0 [F3]</p> <p>[F3]</p>	<div style="border: 1px solid black; padding: 5px; margin-bottom: 5px;"> OFFSET 1/2 F1: ANG. OFFSET F2: DIST. OFFSET F3: PLANE OFFSET </div> <div style="border: 1px solid black; padding: 5px; margin-bottom: 5px;"> ANGLE OFFSET HR: 120° 30' 40" HD: m >Sight? YES NO </div> <div style="border: 1px solid black; padding: 5px; margin-bottom: 5px;"> ANGLE OFFSET HR: 120° 30' 40" HD*[3] -> m <Measuring> </div> <div style="border: 1px solid black; padding: 5px; margin-bottom: 5px;"> ANGLE OFFSET HR: 0° 00' 00" HD m >OK? [YES] [NO] </div> <div style="border: 1px solid black; padding: 5px;"> PT# :F003 PCODE >0 Ref.Hr : 0.000m INPT SRCH MEAS ALL </div>
<p>※1) The factory setting of display is horizontal distance, each time pressing [] key, HD, VD, SD, N, E, Z are shown in sequence, and recorded mode is displayed mode.</p>		

7.8.2 Distance Offset Measurement

The measurement of an object point apart from a prism is possible by inputting offset horizontal distance of front or back/right or left.

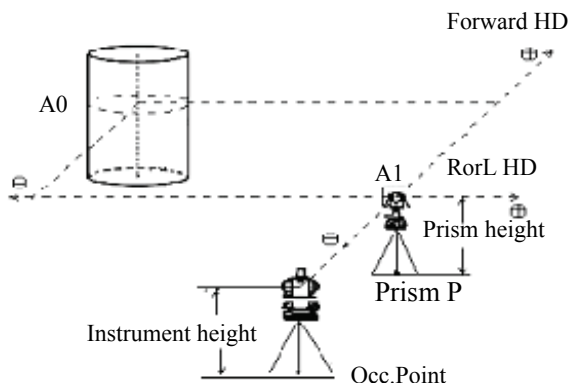

When measuring coordinates of ground point A1: set the instrument height and prism height. When measuring A0: set instrument height only.

Make sure the mode is Data Collect.

Operating procedure	Operation	Display
① Press the [F3] (MEAS) key	[F3]	<pre>PT# :F003 PCODE >0 Ref.Hr : 0.000m INPT SRCH MEAS ALL</pre> <hr/> <pre>VH HD NEZ OFST</pre>
② Press the [F4] (OFST) key.	[F4]	<pre>OFFSET 1/2 F1: ANG. OFFSET F2: DIST. OFFSET F3: PLANE OFFSET</pre>

<p>③ Press the [F2] key (DIST OFFSET).</p> <p>④ Enter Right or Left distance offset value; press [F4] to confirm.</p> <p>⑤ Enter forward distance offset value; press [F4] to confirm.</p> <p>⑥ Enter the PT#, PCODE, Ref.Hr. Collimate the prism, select measuring mode as distance or coordinate, and then begin measure distance.</p> <p>⑧ Measured data is shown, press [F3] (YES) the data is recorded and the next measuring point is displayed.</p>	<p>[F2]</p> <p>[F4]</p> <p>[F4]</p> <p>Collimate prism SD</p> <p>[F3]</p>	<div data-bbox="550 120 871 278"> <p>DISTANCE OFFSET INPUT RorL HD oHD: m --- --- CLR ENT</p> </div> <div data-bbox="550 286 871 445"> <p>DISTANCE OFFSET INPUT RorL HD oHD=1_ --- --- CLR ENT</p> </div> <div data-bbox="550 452 871 611"> <p>DISTANCE OFFSET INPUT FORWARD HD oHD=2_ --- --- CLR ENT</p> </div> <div data-bbox="550 618 871 777"> <p>PT# >F003 PCODE :M Ref.Hr : 1.000m --- SD COOR ---</p> </div> <div data-bbox="550 785 871 943"> <p>VZ: 95° 55' 50" HR: 117° 17' 22" SD: 10.360m >OK? [YES] [NO]</p> </div> <div data-bbox="550 951 871 1110"> <p>PT# :F004 PCODE: Ref.Hr : 0.000m INPT SRCH MEAS ALL</p> </div>
--	---	---



7.8.3 Plane Offset Measurement

Measuring will be taken for the place where direct measuring can not be done, for example distance or coordinate measuring for a edge of a plane.

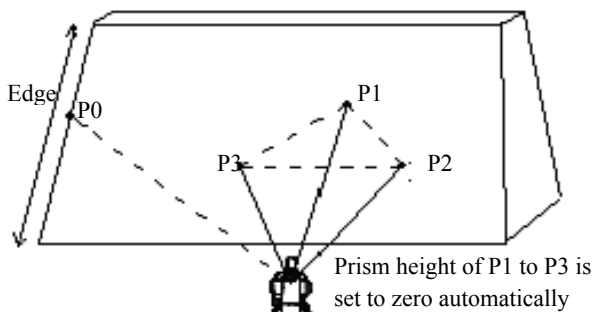
Three random points (P1, P2, P3) on a plane will be measured at first in the plane offset measurement to determine the measured plane, collimate the measuring point (P0), the instrument calculates and displays coordinate and distance value of cross point between collimation axis and of the plane.





Operating procedure	Operation	Display
① Press the [F3] (MEAS) key	[F3]	<div style="border: 1px solid black; padding: 5px;"> PT# :F004 PCODE >0 Ref.Hr : 0.000m INPT SRCH MEAS ALL </div>
② Press the [F4] (OFST) key.	[F4]	<div style="border: 1px solid black; padding: 5px;"> VH HD NEZ OFST </div> <div style="border: 1px solid black; padding: 5px;"> OFFSET 1/2 F1: ANG. OFFSET F2: DIST. OFFSET F3: PLANE OFFSET </div>

Operating procedure	Operation	Display
<p>③ Press the [F3] key (plane offset).</p> <p>④ Collimate point P1, and press the [F1] (MEAS) key to measure. After measuring, the display will show the second point measurement.</p> <p>⑤ Collimate point P2, and press the [F1] (MEAS) key to measure.</p> <p>⑥ Collimate point P3, and press the [F1] (MEAS) key to measure.</p> <p>⑦ Collimate the point P0 on plane edge.</p> <p>⑧ Press the F4 (MEAS) key, the instrument calculates and displays coordinate and distance value of cross point between collimation axis and of the plane. ※1) ※2)</p> <p>⑨ Press  or  to show different display mode in sequence. ※3)</p> <p>⑩ Press the [F3] (YES) key to confirm and record, the display returns to the next point number in Plane Offset menu.</p>	<p>[F3]</p> <p>Collimate P1</p> <p>[F1]</p> <p>Collimate P2</p> <p>[F1]</p> <p>Collimate P3</p> <p>[F1]</p> <p>Collimate P0</p> <p>[F4]</p>	<pre> PLANE N001# SD: m MEAS --- --- --- LANE N002# SD: m MEAS --- --- --- PLANE N003# SD: m MEAS --- --- --- PLANE PT# >F004 PCODE: V INPT SRCH --- MEAS HR : 12° 34' 56" HD : 1.234m VD : 0.000m > OK? [YES] [NO] N: 1.234m E: 1.234m Z: 1.234m > OK? [YES] [NO] PLANE PT# >F005 PCODE: V INPT SRCH --- MEAS </pre>

※1) In case the calculation of plane was not successful by the measured three points, error displays. Start measuring over again from the first point.

※2) Error will be displayed when the collimated direction does not cross with the determined plane.

※3) Each time pressing [] or [] key, HD, VD, SD, N, E, Z are shown in sequence, and the recorded mode is as displayed mode.



7.8.4 Column Offset Measurement

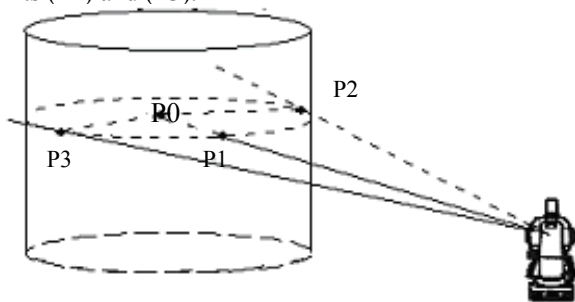

It is possible to measure circumscription point (P1) of column directly, the distance to the center of the column (P0), coordinate and direction angle can be calculated by measuring circumscription points (P2) and (P3)

The direction angle of the column center is average of circumscription points (P2) and (P3).



Operating procedure	Operation	Display
① Press the [F3] key (MEAS)	[F3]	<pre> PT# :F005 PCODE >0 Ref.Hr : 0.000m INPT SRCH MEAS ALL </pre>
② Press the [F4](OFST) key, press [] key to show next page.	[F4] [EDM]	

<p>③ Press the [F1] (column offset) key.</p> <p>④ Collimate the center of column P1, and press the [F1] (MEAS) key to measure N times.</p> <p>⑤ Collimate the left side of the column (P2) and press the [F4] (SET) key.</p> <p>⑥ Collimate the right side of the column (P3) and press the [F4] (SET) key.</p> <p>⑦ The distance between the instrument and center of the column (P0) will be calculated and shown.</p> <p>⑧ Press  or  to show different display mode in sequence. ※1)</p> <p>⑨ Press the [F3] (YES) key to confirm and record.</p>	<p>Collimate P1 [F1]</p> <p>Collimate P2 [F4]</p> <p>Collimate P3 [F4]</p> <p>[F3]</p>	<div data-bbox="574 126 896 281"> <p>OFFSET 2/2 F1: COLUMN OFFSET</p> </div> <div data-bbox="574 296 896 452"> <p>COLUMN OFFSET Center HD: m MEAS --- --- ---</p> </div> <div data-bbox="574 467 896 623"> <p>COLUMN OFFSET Center HD* 1.234m < Measuring ></p> </div> <div data-bbox="574 638 896 793"> <p>COLUMN OFFSET Left HR: 12° 34' 56" --- --- --- SET</p> </div> <div data-bbox="574 808 896 964"> <p>COLUMN OFFSET Right HR: 12° 34' 56" --- --- --- SET</p> </div> <div data-bbox="574 979 896 1135"> <p>COLUMN OFFSET HR: 12° 34' 56" HD: 1.234m > OK? [YES] [NO]</p> </div> <div data-bbox="574 1150 896 1305"> <p>COLUMN OFFSET HR: 12° 34' 56" VD: 0.000m > OK? [YES] [NO]</p> </div>
---	--	--

※1) Each time pressing [] or  key, HD, VD, SD, N, E, Z are shown in sequence, and the recorded mode is displayed mode.

7.9 NEZ Auto Calculation

As measured data is collected, coordinates are calculated and stored for traverse or topo collection. Automatic making out function of coordinate data sets up in CONFIG of data collect. Refer to Section 7.10 “Setting Parameter of Data Collect [CONFIG.]”.

As a default, coordinate data calculated will be saved in a file of the same name as the measurement data file. When the coordinate data file of the same name as the measurement data file does not exist, it will be generated automatically. It is possible to change a file for saving coordinate data in the DATA COLLECT Menu 2/2 (F1: SELECT A FILE).

To calculate a coordinate data, it is necessary to add a point number in Data Collect execution. When a coordinate data of the same point number exist already, it can be replaced with the new data by confirming display.

● Coordinates will be calculated using the grid factor. To set the grid factor, see Section 8.6 “Setting the GRID FACTOR”

7.10 Setting Parameter of Data Collect [CONFIG.]

In this mode, the following settings of data collect mode are possible

● Setting Items:

Menu	Selecting Item	Contents
F1:HD/SD	HD/SD	Select the distance measurement mode Horizontal Distance or Slope distance.
F2:MEAS ORDER	N TIMES/S TIMES/REPEAT	Select to set measurement mode for distance measurement.
F3:DATA CONFIRM	YES/NO	It is possible to confirm the result of measuring data before the data is recorded.
F1:COLLECT ORDER	Edit→Meas/ Meas→Edit	Select the procedure of data collection. [EDIT →MEAS]: Measurement is carried out after entering other data. [MEAS→EDIT]: Measurement is carried out before entering other data.
F2:NEZ AUTO.CALC	ON/OFF	It is possible to calculate coordinate value of data collected and store it into coordinate data file in every data collection.

● How to Set items

Example Setting: DATA CONFIRM: YES

Operating procedure	Operation	Display
①The instrument in Data Collect mode.		<div style="border: 1px solid black; padding: 5px;"> COLLECT 1/2 F1: OCC.PT# INPUT F2: BACKSIGHT F3: FS/SS </div>
②Press [▼] to enter collect menu 2/2.	[▼]	<div style="border: 1px solid black; padding: 5px;"> COLLECT 2/2 F1:SELECT A FILE F2: PCODE INPUT F3:CONFIG </div>
③Press [F3] to show CONFIG menu.	[F3]	<div style="border: 1px solid black; padding: 5px;"> CONFIG F1: HD/SD F2: MEAS ORDER F3: DATA CONFIRM P ↓ </div>
④Press [F3] (DATA CONFIRM).	[F3]	<div style="border: 1px solid black; padding: 5px;"> Data Confirm F1:YES [F2:NO] <div style="text-align: right;">ENT</div> </div>
⑤ Press [F1](YES) key, then press [F4] key to confirm.	[F1] [F4]	<div style="border: 1px solid black; padding: 5px;"> Data Confirm [F1:YES] F2:NO <div style="text-align: right;">ENT</div> </div>

8. Coordinate Layout

Layout mode has two functions which are setting of layout points and setting new points using coordinate data in the internal memory. Also, if the coordinate data is not stored in the internal memory, this can be input from key board. The coordinate data is loaded from PC to the internal memory via RS-232C or USB/SD card.

The coordinate data

The coordinate data is memorized into a file, the memory has three recorded parts, one is for measured data, another is for coordinate data, and the last one is for PCODE data.

For the internal memory, refer to Chapter 10 “Memory Manager Mode”

- 1) When turning off the power, ensure that you are in the main menu screen or angle measurement mode. This ensures completion of the memory access process and avoids possible damage of the stored data.
- 2) It is recommended for safety to charge the battery beforehand and prepared fully charged spare batteries.

8.1 Layout procedures

- 1) Selecting a file for layout.
- 2) Input Occ. point.
- 3) Input backsight point or backsight angle.
- 4) Input or pick-up (from internal memory) the coordinate data for layout point. Start layout.

8.2 Selecting or creating a coordinate data file

You can execute a Layout from selected coordinate data file.

Here one existing coordinate data file can be selected; also you can input a new file name to create one new file for coordinate layout

Operating procedure	Operation	Display
① Press [MENU] key, the instrument will be in MENU mode.	[MENU]	<pre> MENU 1/3 F1: DATA COLLECT F2: LAYOUT F3: MEMORY MGR P ↓ </pre>
② Press [F2] key, to enter file selecting menu.	[F2]	<pre> SELECT A CFILE FN: INPT LIST SKIP ENT </pre>
③ Press [F2] key to display the list of coordinate data file. ※1) ※2)	[F1]	<pre> > *1 /C0002 1SV /C0000 TOP LAST SRCH ENT </pre>
④ Scoll file list by pressing the [▲]or[▼]key and select a file to use.※3)	[▼] [F3]	<pre> *1 /C0002 > 1SV /C0000 S /C0000 TOP LAST SRCH ENT </pre>
⑤ Press [F4] key, the file will be selected. Instrument enters Layout Menu.		<pre> Layout 1/2 F1: OCC. PT# INPUT F2: BACKSIGHT F3: LAYOUT P ↓ </pre>

- ※1) If you want to input file name directly, press[F1]key to enter.
- ※2) If you input a file name that it is not found in memory, a new coordinate with input name will be created automatically.
- ※3) When a file has been selected already, mark .“@”is indicated on left of current file name.
- It is possible to select a file from Layout 2/2, menu in the same way.

8.3 Occupied Point Setting

1) Setting the coordinate data from the internal memory.

Example: Confirm the coordinate data file has been selected already

Operating procedure	Operation	Display
<p>①The instrument be in LAYOUT mode.</p> <p>②Press [F1] key.</p> <p>③Press [F2] key. ※1)</p> <p>④Press [▲] or [▼] key to select PT#. ※2) ※3) Press [F4] key to confirm.</p> <p>⑤ Press [F3] key to select YES.</p> <p>⑥Input Ins.Hi. Range:-999.999~+999.999m Press [F4] key.</p>	<p>[F1]</p> <p>[F2]</p> <p>[F4]</p> <p>[F3]</p> <p>[F4]</p>	<div style="border: 1px solid black; padding: 5px; margin-bottom: 5px;"> Layout 1/2 F1: OCC. PT# INPUT F2: BACKSIGHT F3: LAYOUT P ↓ </div> <div style="border: 1px solid black; padding: 5px; margin-bottom: 5px;"> OCC. PT PT# : INPT LIST NEZ ENT </div> <div style="border: 1px solid black; padding: 5px; margin-bottom: 5px;"> > 2 1 VIEW SRCH --- ENT </div> <div style="border: 1px solid black; padding: 5px; margin-bottom: 5px;"> N 5.620m E 4.210m Z 1.250m >OK? [YES] [NO] </div> <div style="border: 1px solid black; padding: 5px;"> INSTRUMENT HEIGHT INPUT Ins.Hi =1.000 m --- --- CLR ENT </div>
<p>※1) Direct input PT#: Press [F1] key and input PT#.</p> <p>※2) The selected coordinate data can be viewed by press[F1](VIEW) key.</p> <p>※3) The coordinate data can be searched by press[F2](SRCH).</p>		

2) Input the instrument point coordinates by hand

Make sure the coordinate data file is selected.

Operating procedure	Operation	Display
①Layout menu.		<div style="border: 1px solid black; padding: 5px;"> Layout 1/2 F1: OCC. PT# INPUT F2: BACKSIGHT F3: LAYOUT </div>
②Press [F1] key.	[F1]	<div style="border: 1px solid black; padding: 5px;"> OCC. PT PT# INPT LIST NEZ ENT </div>
③Press [F3] (NEZ) key to coordinate inputting mode.	[F3]	<div style="border: 1px solid black; padding: 5px;"> N > 0.000m E 0.000m Z 0.000m INPT --- PT ENT </div>
④Press [F1] key and enter N coordinate value; press [F4] to confirm.	[F1]	<div style="border: 1px solid black; padding: 5px;"> N = 123.456_ m E : 0.000 m Z : 0.000 m --- --- CLR ENT </div>
※ 1) ⑤Enter E coordinate, press [F4] to confirm.	[F4]	<div style="border: 1px solid black; padding: 5px;"> N: 123.456 m E= 987.65_ m Z : 0.000 m --- --- CLR ENT </div>
※ 2) ⑥Enter Z coordinate, and press [F4].	[F4]	<div style="border: 1px solid black; padding: 5px;"> N: 123.456 m E: 987.65 m Z= -1.608_ m --- --- CLR ENT </div>

Operating procedure	Operation	Display
<p>⑦ Press[F3](YES) key to record the inputted data to memory. ※ 1)</p> <p>⑧ Input the PT# for input coordinate, press [F4] key.</p> <p>⑨ Input the instrument height. Press [F4] key to confirm.</p> <p>⑩ Back to Layout menu.</p>	<p>[F4]</p> <p>Input PT# [F4]</p> <p>Input Instr.H [F4]</p>	<div data-bbox="510 176 830 354" style="border: 1px solid black; padding: 5px;"> <p>N: 123.456 m E: 987.65 m Z: -1.608 m >REC ? [YES] [NO]</p> </div> <div data-bbox="510 375 830 532" style="border: 1px solid black; padding: 5px;"> <p>INPUT COORD PT# : INPT LIST --- ENT</p> </div> <div data-bbox="510 569 830 727" style="border: 1px solid black; padding: 5px;"> <p>INTRUMENT HEIGHT INPUT Ins.Hi=1.5 _ --- --- CLR ENT</p> </div> <div data-bbox="510 742 830 899" style="border: 1px solid black; padding: 5px;"> <p>Layout 1/2 F1: OCC. PT# INPUT F2: BACKSIGHT F3: LAYOUT</p> </div>
<p>※1) The item following “<” is current inputting item. After the inputting of this item press F4 to confirm, the mark “<”will move downward to another item. Otherwise, press ▼ the cursor “<” will also move to other item.</p> <p>※2) If the setting of MANUAL NEZ REC is OFF at parameters menu, the PT# inputting screen will not display, and the inputted coordinates isn't recorded to memory, and can not be recalled from memory in the future.</p>		

3) Input the point number of occupied point directly

Refer to Chapter 7.2 to select the Coordinate data file

Operating procedure	Operation	Display
①The instrument be in LAYOUT mode.		<div style="border: 1px solid black; padding: 5px;"> Layout 1/2 F1: OCC. PT# INPUT F2: BACKSIGHT F3: LAYOUT </div>
②Press [F1] key.	[F1]	<div style="border: 1px solid black; padding: 5px;"> OCC. PT PT# : INPT LIST NEZ ENT </div>
③Press [F1] key to enter the point number, and press [F4] to confirm.	[F1] Enter PT# [F4]	<div style="border: 1px solid black; padding: 5px;"> OCC. PT PT# =F023_ ALPH SPC CLR ENT </div>
④The coordinate value will display.		<div style="border: 1px solid black; padding: 5px;"> N 5.620m E 4.210m Z 1.250m YES NO </div>
⑤ Press [F3] key to select YES.	[F3]	<div style="border: 1px solid black; padding: 5px;"> INTRUMENT HEIGHT INPUT Ins.Hi=1.5_ --- --- CLR ENT </div>
⑥Input Ins.Hi. Range:-99.999~ +99.999m Press [F4] key to confirm, instrument will back to Layout menu automatically.	Input Inst.H [F4]	<div style="border: 1px solid black; padding: 5px;"> Layout 1/2 F1: OCC. PT# INPUT F2: BACKSIGHT F3: LAYOUT </div>

8.4 Setting Backsight Point

1) Setting the coordinate data file from the internal memory

Make sure the instrument displays layout menu

Operating procedure	Operation	Display
① Press [F2] (BACKSIGHT) key to set backsight point.	[F2]	BACKSIGHT PT# INPT LIST NEAZ ENT
② Press [F2] key to view data file. ※1) ※2)	[F2]	> 2 1 VIEW SRCH --- ENT
③ Press [▲] or [▼] key to select PT#. Press [F4] key.	[▼] [F4]	N 1.000m E 2.000m Z 1.100m >OK? [NO] [YES]
④ The coordinate value will display. Press [F4] key to select YES. ※3)	[F4]	BACKSIGHT HR:283° 25' 33" >Sight? --- dHD YES NO
⑤ Collimate backsight, press [F3] key and return back the layout menu. ※4)	Collimate backsight [F3]	Layout 1/2 F1: OCC. PT# INPUT F2: BACKSIGHT F3: LAYOUT P ↓

※1) Press [F1](VIEW) key the coordinate data values can be displayed.

※2) Press [F2](SRCH) key the coordinate data can be searched by entering PT#.

※3) Press [F4](NO) key return to points list menu.

※4) Press[F2](dHD) to measure the difference between calculated backsight and true backsitht

2) Direct key input of coordinate data

Make sure the instrument displays layout menu

Operating procedure	Operation	Display
<p>① Press [F2] key to enter backsight point setting screen.</p> <p>② Press [F3] (NEAZ) key. ※1)</p> <p>③ Press [F1] key and enter N, E, Z coordinates in turns. Press [F4] key. ※2)</p> <p>④ Press [F3] key to record the input data.</p> <p>⑤ Press [F1] to input PT#, then press [F4] to confirm.</p> <p>⑥ Collimate backsight, press [F3] key and return back the layout menu. ※3)</p>	[F2]	<pre>BACKSIGHT PT# : INPT LIST NEAZ ENT</pre>
	[F3]	<pre>N > 0.000m E : 0.000m Z : 0.000m INPT --- AZ ENT</pre>
	[F1]	<pre>N: 123.450m E: 987.640m Z= 564.230_ --- --- CLR ENT</pre>
	[F4]	<pre>N: 123.450m E : 987.640m Z : 564.230 >REC ? [YES][NO]</pre>
	[F3]	<pre>INPUT COORD PT#: INPT LIST --- ENT</pre>
	[F4]	<pre>BACKSIGHT HR:283° 25' 33" >Sight? dHD YES NO</pre>
	[F3]	
	<p>※1) With each pressing of [F3] key, switched among PT#, NEAZ (coordinate) and AZ (backsight angle).</p>	

※2) The item following “<” is current inputting item. After the inputting of this item press F4 to confirm, the mark “<” will move downward to another item. Otherwise, press ▼ the cursor “<” will also move to other item.

※3) Press[F2](dHD) to measure the difference between calculated backsight and true backsight.

3) Direct key input of setting angle.

Make sure the instrument displays layout menu

Operating procedure	Operation	Display
① Press [F2] key.	[F2]	<pre> BACKSIGHT PT# : INPT LIST NEAZ ENT </pre>
② Press[F3](NEAZ) key. ※1)	[F3]	<pre> N > 0.000m E: 0.000m Z: 0.000m INPT --- AZ ENT </pre>
③ Press [F3] (AZ) key.	[F3]	<pre> BACKSIGHT HR: </pre>
④ Press [F1] key and enter setting angle. 123°16'18"	[F1]	<pre> INPT ---- PT# ENT </pre>
Press [F4] key.	[123.16 18]	<pre> BACKSIGHT HR =123.1618 </pre>
⑤ Collimate backsight, press [F3] key and return back the layout menu.	[F4] Collimate backsight [F3]	<pre> --- --- CLR ENT </pre> <pre> BACKSIGHT HR :123° 16' 18" >Sight? YES NO </pre>

※1) With each pressing of [F3] key, switched among PT#, NE (coordinate) and AZ (backsight angle).

8.5 Executing a Layout

The following methods can be selected for executing a layout.

- 1) Recalling points from internal memory by point number.
- 2) Direct key input of coordinate values.

Example setting: recalling point from internal memory

Operating procedure	Operation	Display
① Make sure the displaying is layout menu.		<pre>Layout 1/2 F1: OCC. PT# INPUT F2: BACKSIGHT F3: LAYOUT P ↓</pre>
② Press [F3] (LAYOUT) key.	[F3]	<pre>LAYOUT PT#: INPT LIST NEZ ENT</pre>
③ Press [F2] (LIST) key. ※1)	[F2]	<pre>[FOIFMA] > 2 1 VIEW SRCH --- ENT</pre>
④ Press [▲] or [▼] key to select PT#. Press [F4] key. ※2) ※3)	[F4]	<pre>N: 2.615m E: 3.186m Z: 1.268m >OK? [YES] [NO]</pre>
⑤ Press [F3] (YES) key to confirm the coordinate. ※4)	[F3]	
⑥ Input target height Ref.Hr.		<pre>REF HT INPUT</pre>
⑦ Press [F4] key.	[F4]	<pre>Ref.Hr=1.75_ --- --- CLR ENT</pre>
HR: calculated horizontal angle of the layout point HD: Calculated horizontal distance from the instrument		<pre>CALCULATED HR: 44° 38' 29" HD: 173.464m ANG DIST --- ---</pre>

<p>When the display value dHR, dHD and dZ are equal to 0, the layout point is established. ※4) ※5)</p> <p>① Press [F3] (ANG) key to setting screen, press [F3] (CORD) key again, the coordinate data is shown. Press [F2] mode key to setting the distance measuring mode.</p> <p>③ Press [F4] key to set next layout point.</p>	<p>[F3]</p> <p>[F3]</p>	<div data-bbox="634 157 954 314" style="border: 1px solid black; padding: 5px;"> <p>dHR: 000° 00' 12" dHD: -0.001 m dZ: -0.002 m DIST MODE ANG NEXT</p> </div> <div data-bbox="634 332 948 489" style="border: 1px solid black; padding: 5px;"> <p>PT#: HR: 44° 38' 29" dHR: 30° 38' 29" DIST --- CORD ---</p> </div> <div data-bbox="634 507 948 664" style="border: 1px solid black; padding: 5px;"> <p>N: 56.287 m E: 986.321 m Z: 123.345 m DIST MODE ANG NEXT</p> </div> <div data-bbox="634 676 948 834" style="border: 1px solid black; padding: 5px;"> <p>LAYOUT PT#: INPT LIST NEZ ENT</p> </div>
<p>※1) If you want to input PT# directly, press [F1]key and enter PT#.</p> <p>※2) The coordinate data can be viewed by press [F1]key.</p> <p>※3) The coordinate data can be searched by press [F2]key and enter PT#.</p> <p>※4) As normal, rotating the horizontal circle and make dHR reach 0. Setting the prism as this direction. Make the dHD and dZ reach 0 by distance measured.</p> <p>※5) Cut&Fill displaying function is available. Refer to Chapter 13 “Selecting Mode”.</p> <p>NOTE: After layout, collimate the layout point and measure it’s coordinate, and then confirm its accuracy, the measurement mode can be selected.</p>		

8.6 Setting the GRID FACTOR

Calculation Formula

1. Elevation Factor = $R/(R+ELEV)$

R: The average radius of the earth

ELEV. : The elevation above mean sea level

2. Scale Factor

Scale Factor: Scale Factor at the surveying station

3. Grid Factor

Grid Factor=Elevation Factor×Scale Factor

Distance Calculation

1. Grid Distance

HDg=HD ×Grid Factor

HDg: Grid distance

HD: Ground distance

2. Ground Distance

HD= HDg/ Grid Factor

After the Grid Factor setting is finished, it is used for layout and other coordinate measurement programs.

Operating procedure	Operation	Display
①Displayed the layout menu 2/2.		<div style="border: 1px solid black; padding: 5px;">Layout 2/2 F1: SELECT A FILE F2: GRID FACTOR</div>
②Press [F2] key.	[F2]	<div style="border: 1px solid black; padding: 5px;">GRID FACTOR =1.000000 > MODIFY? YES NO</div>

Operating procedure	Operation	Display
<p>③Press [F3]key.※1)</p> <p>④Enter Elevation. ※2) Press [F4] to confirm.</p> <p>⑤Enter Scale Factor. Press [F4]key.※3)</p> <p>⑥Press [F4] key. Grid Factor is displayed, and then returns to Layout menu automatically. ※4)</p>	<p>[F3]</p> <p>enter</p> <p>Elevation</p> <p>[F4]</p> <p>enter</p> <p>Scale Factor</p> <p>[F4]</p>	<div data-bbox="626 178 944 333" style="border: 1px solid black; padding: 5px;"> <pre> GRID FACTOR ELEV.=0_ 0 m SCALE : 1.000000 --- --- CLR ENT </pre> </div> <div data-bbox="626 356 944 511" style="border: 1px solid black; padding: 5px;"> <pre> GRID FACTOR ELEV.= 1000 m SCALE: 1.000000_ --- --- CLR ENT </pre> </div> <div data-bbox="626 571 944 727" style="border: 1px solid black; padding: 5px;"> <pre> GRID FACTOR =1.000685 </pre> </div>
<p>※1) Press[F4] key if don't need to changed the Grid Factor.</p> <p>※2) Elevation enter range:-9999m ~ +9999m.</p> <p>※3) Scale enter range:0.990000 ~ 1.010000.</p> <p>※4) In Resection program, the Grid Factor need be reset to calculate the error, refer to the procedures from step 2 to step 5 to do that.</p>		

9. Application Measurement (Programs)

9.1 Remote Elevation Measurement (REM)

Two mode of with prism and without prism can be selected to measure the vertical height from target to prism or ground point, the prism or ground point should be on the vertical line from the target.

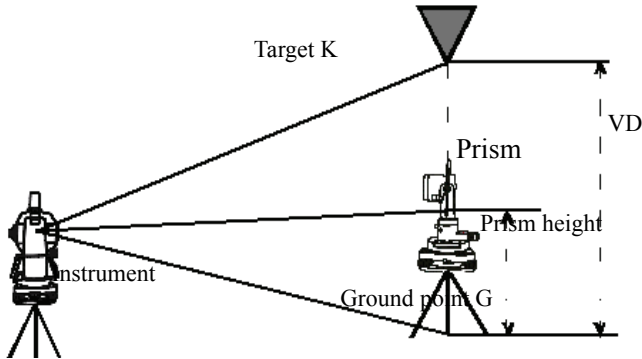

1) With prism height (h) input (Example: h=1.5m)

Operating procedure	Operation	Display								
① Press the [MENU] key to menu mode.	[MENU]	<table border="1"> <tr> <td>MENU</td> <td>2/3</td> </tr> <tr> <td>F1:PROGRAMS</td> <td></td> </tr> <tr> <td>F2:PARAMETERS 1</td> <td></td> </tr> <tr> <td>F3:CONTRAST</td> <td>P ↓</td> </tr> </table>	MENU	2/3	F1:PROGRAMS		F2:PARAMETERS 1		F3:CONTRAST	P ↓
MENU	2/3									
F1:PROGRAMS										
F2:PARAMETERS 1										
F3:CONTRAST	P ↓									
② Press the [F1] (PROGRAMS) key.	[F1]	<table border="1"> <tr> <td>PROGRAMS</td> <td>1/2</td> </tr> <tr> <td>F1: REM</td> <td></td> </tr> <tr> <td>F2: MLM</td> <td></td> </tr> <tr> <td>F3: Z COORD</td> <td></td> </tr> </table>	PROGRAMS	1/2	F1: REM		F2: MLM		F3: Z COORD	
PROGRAMS	1/2									
F1: REM										
F2: MLM										
F3: Z COORD										

2) Without prism height input

Operating procedure	Operation	Display
① Press the [MENU] key to menu mode.		<pre>PROGRAMS 1/2 F1: REM F2: MLM F3: Z COORD</pre>
② Press the [F1] (REM) key.	[F1]	<pre>REM F1: INPUT R.HT F2: NO R.HT</pre>
③ Press the [F2] (NO R.HT) key.	[F2]	<pre>REM-2 <STEP-1> HD: m MEAS --- --- ---</pre>
④ Collimate prism Press the [F1] (MEAS) key, measuring starts, horizontal distance (HD) between instrument and prism will be decided.	Collimate P [F1]	<pre>REM-1 <STEP-1> HD: * 6.888 m <Measuring></pre>
⑤ Vertical angle(VZ) will be shown	[F4]	<pre>REM-2 <STEP-2> VZ: 6° 30' 25 " --- --- --- SET</pre>
⑥ Press the [F4](SET) key. The prism position will be decided.		<pre>REM-2 VD: 0.000m --- VZ HD ---</pre>
⑦ Collimate ground point G. The position of point G will be decided. *1	Collimate G [F4]	<pre>REM-2 VD: 6.580m --- VZ HD ---</pre>
⑧ Collimate target K. Vertical distance (VD) will be shown. *2	Collimate K	

- *1) To return to procedure 4, press the [F3](HD) key.
 To return to procedure 5, press the [F2](VZ) key.
 *2) To return to PROGRAMS Menu, press the [ESC] key.

9.2 Missing Line Measurement (MLM)

9.2.1 Missing Line Measurement

Measurement for horizontal distance (dHD), slope distance (dSD), elevation (dVD) between two targets. MLM has two modes:

1. MLM-1 (A-B, A-C): Measurement is A-B, A-C, A-D.....
2. MLM-2 (A-B, B-C): Measurement is A-B, B-C, C-D.....

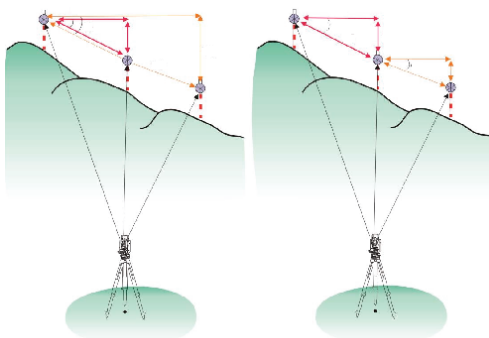

MLM-1

MLM-2

[Example]1. MLM-1 (A-B, A-C)

Procedure of MLM-2 (A-B, B-C) mode same as MLM-1 mode

Operating procedure	Operation	Display
① Press the [MENU] key to menu mode.		PROGRAMS 1/2
② Press the [F2] (MLM) key.	[F2]	F1: REM F2: MLM F3: Z COORD
③ Press the [F1] or [F2] key to select using	[F2]	MLM F1:USE FILE F2:DON' T USE

9.2.2 USE FILE and GRID FACTOR

Operating procedure	Operation	Display
<p>① Make sure the display is in [PROGRAMS] mode.</p> <p>② Press the [F2] (MLM) key.</p> <p>③ Press [F1] (USE FILE) key</p> <p>④ Select a coordinate file.</p> <p>⑤ Press [F1] (F1:USE) to confirm.</p> <p>⑥ Press [F3] (YES) to confirm the Grid Factor.</p> <p>⑦ Repeat 9.2.1 step ④ - ⑩</p>	<p>[F2]</p> <p>[F1]</p> <p>[F4]</p> <p>[F3]</p>	<div data-bbox="550 216 868 375" style="border: 1px solid black; padding: 5px;"> PROGRAMS 1/2 F1: REM F2: MLM F3: Z COORD </div> <div data-bbox="550 387 868 546" style="border: 1px solid black; padding: 5px;"> MLM F1: USE FILE F2: DON'T USE </div> <div data-bbox="550 557 868 716" style="border: 1px solid black; padding: 5px;"> SELECT A CFILE FN:1SV INPUT LIST --- ENT </div> <div data-bbox="550 728 868 887" style="border: 1px solid black; padding: 5px;"> GRID FACTOR F1: USE F2: Not Use </div> <div data-bbox="550 899 868 1058" style="border: 1px solid black; padding: 5px;"> GRID FACTOR =1.000000 >OK? [YES][NO] </div> <div data-bbox="550 1069 868 1228" style="border: 1px solid black; padding: 5px;"> MLM F1: MLM-1 A-B ,A-C F2: MLM-2 A-B,B-C </div>

9.3 Setting Z Coordinate of Occupied Point

Input occupied point coordinate data, with known point actual measuring data, Z coordinate of occupied point is calculated and reset again. Known point data and coordinate data can recalled from the coordinate data file.

1) Setting coordinate data file (if you don't recall data from memory, please ignore this operation step)

Operating procedure	Operation	Display
①Display PROGRAMS menu on page 1.		<pre>PROGRAM 1/2 F1: REM F2: MLM F3: Z COORD</pre>
②Press the [F3] (Z COORD) key	[F3]	<pre>Z COORD. SETTING F1: USE FILE F2: DON'T USE</pre>
③Press the [F1] (USE FILE) key.	[F1]	<pre>SELECT A FILE FN: INPT LIST --- ENT</pre>
④Press the [F2] (LIST) key, the list of coordinate data files are shown.※1)	[F2]	<pre>>&1 /C0002 1SV /C0000 TOP LAST SRCH ENT</pre>
⑤press [▲] or [▼] keys, the cursor will move up or down one by one, select a file.※2)	[▼]	<pre>&1 /C0002 > 1SV /C0000 TOP LAST SRCH ENT</pre>

⑥Press the [F4] key to confirm.	[F4]	<div style="border: 1px solid black; padding: 5px;"> Z COORD. SETTING F1: OCC. PT INPUT F2: REF. MEAS </div>
※1) Press the [F1](INPT) key to enter file name directly. ※2) Press the [F3](SRCH) key to scan the coordinate data in the selected file		

2) Setting the Coordinate of occupied point

Operating procedure	Operation	Display
①Make sure the displaying is in Z Coordinate mode ②Press the [F1] key (OCC. PT INPUT) ③Press the [F2](LIST) key to display coordinates list.※1) ※2) ④Press [▲] or [▼] keys, the cursor will move up or down one by one, select a point. Press the [F4] key to confirm※3) ⑤The coordinate value will be shown, press the [F3] (YES) key to confirm. ⑥Input the instrument	 [F1] [F2] [F4] [F3]	<div style="border: 1px solid black; padding: 5px;"> Z COORD. SETTING F1: OCC. PT INPUT F2: REF. MEAS </div> <div style="border: 1px solid black; padding: 5px; margin-top: 5px;"> OCC.PT PT#: </div> <div style="border: 1px solid black; padding: 5px; margin-top: 5px;"> INPT LIST NEZ ENT </div> <div style="border: 1px solid black; padding: 5px; margin-top: 5px;"> >2 1 </div> <div style="border: 1px solid black; padding: 5px; margin-top: 5px;"> VIEW SRCH --- ENT </div> <div style="border: 1px solid black; padding: 5px; margin-top: 5px;"> N: 1002.362m E: 566.231m Z: 100.002m >OK? YES NO </div> <div style="border: 1px solid black; padding: 5px; margin-top: 5px;"> INSTRUMENT HEIGHT INPUT Ins.HT=1.000 m --- --- CLR ENT </div>

height and press the [F4] to confirm.	Enter I.HT [F4]	<div style="border: 1px solid black; padding: 5px;"> Z COORD. SETTING F1: OCC. PT INPUT F2: REF. MEAS </div>
---------------------------------------	-----------------------	--

- ※1) Press the [F1] (INPT) key to input point number directly.
※2) Press the [F3] (NEZ) key to input coordinate data directly.
※3) Press the [F1] (VIEW) key to scan the coordinate data in the selected file.

3) Z Coordinate Calculation from Known Point Measuring Data

Example: Using coordinate data file

Operating procedure	Operation	Display
①The display return to Z Coordinate program after selected the coordinate for occupied point.		<div style="border: 1px solid black; padding: 5px;"> Z COORD. SETTING F1: OCC. PT INPUT F2: REF. MEAS </div>
②Press the [F2] key. (REF. MEAS)	[F2]	<div style="border: 1px solid black; padding: 5px;"> N001# PT#: </div>
③Press [F2] (LIST) key to open the data list, select a point, press [F3] (YES) to confirm.	[F2] Select PT# [F3]	<div style="border: 1px solid black; padding: 5px;"> INPT LIST NEZ ENT N: 1002.362m E: 566.231m Z: 100.002m >OK? YES NO </div>
④Press [F1](INPT) to input prism height R.HT Press [F4] to confirm.	[F1] Input R.HT [F4]	<div style="border: 1px solid black; padding: 5px;"> REF HT INPUT Ref.Hr=1.500_ m --- --- CLR ENT </div>

<p>⑤ Collimate prism Press the [F3] (YES) key to start measure distance.</p> <p>⑥ Press the [F4] (CALC) key, the result will be shown. ※1) Z:Z coordinate dZ: standard error</p> <p>⑦ Press the [F4] (SET) key, the result will be set as the Z coordinate of occupied point. Backsight point measuring screen will be shown. ※2)</p> <p>⑧ If press the [F3](YES) key, azimuth angle will be set, the display returns to Z coordinate program mode</p>	<p>Collimate P</p> <p>[F3]</p> <p>[F4]</p> <p>[F4]</p> <p>[F3]</p>	<table border="1" style="width: 100%; border-collapse: collapse;"> <tr> <td colspan="3" style="text-align: center;">REF HT INPUT</td> </tr> <tr> <td style="width: 30%;">Ref.</td> <td style="width: 40%; text-align: right;">1.5m</td> <td></td> </tr> <tr> <td>> SIGHT?</td> <td style="text-align: center;">YES</td> <td style="text-align: center;">NO</td> </tr> <tr> <td colspan="3" style="text-align: center;">> Measuring.....</td> </tr> </table> <table border="1" style="width: 100%; border-collapse: collapse;"> <tr> <td style="width: 30%;">HR:</td> <td style="width: 40%; text-align: right;">142° 23' 59"</td> <td></td> </tr> <tr> <td>HD:</td> <td style="text-align: right;">15.8m</td> <td></td> </tr> <tr> <td>VD:</td> <td style="text-align: right;">10.3m</td> <td></td> </tr> <tr> <td>NEW</td> <td style="text-align: center;">---</td> <td style="text-align: center;">---</td> </tr> <tr> <td colspan="3" style="text-align: right;">CALC</td> </tr> </table> <table border="1" style="width: 100%; border-collapse: collapse;"> <tr> <td colspan="3" style="text-align: center;">Z COORD. SETTING</td> </tr> <tr> <td style="width: 30%;">Z</td> <td style="width: 40%; text-align: right;">12.345m</td> <td></td> </tr> <tr> <td>dZ</td> <td style="text-align: right;">0.000m</td> <td></td> </tr> <tr> <td>---</td> <td style="text-align: center;">---</td> <td style="text-align: center;">BS SET</td> </tr> </table> <table border="1" style="width: 100%; border-collapse: collapse;"> <tr> <td colspan="3" style="text-align: center;">BACK SIGHT</td> </tr> <tr> <td style="width: 30%;">HR:</td> <td style="width: 40%; text-align: right;">180° 00' 00"</td> <td></td> </tr> <tr> <td>> Sight?</td> <td style="text-align: center;">YES</td> <td style="text-align: center;">NO</td> </tr> </table> <table border="1" style="width: 100%; border-collapse: collapse;"> <tr> <td style="width: 70%;">PROGRAM</td> <td style="width: 30%; text-align: right;">1/2</td> </tr> <tr> <td>F1: REM</td> <td></td> </tr> <tr> <td>F2: MLM</td> <td></td> </tr> <tr> <td>F3: Z COORD</td> <td></td> </tr> </table>	REF HT INPUT			Ref.	1.5m		> SIGHT?	YES	NO	> Measuring.....			HR:	142° 23' 59"		HD:	15.8m		VD:	10.3m		NEW	---	---	CALC			Z COORD. SETTING			Z	12.345m		dZ	0.000m		---	---	BS SET	BACK SIGHT			HR:	180° 00' 00"		> Sight?	YES	NO	PROGRAM	1/2	F1: REM		F2: MLM		F3: Z COORD	
REF HT INPUT																																																										
Ref.	1.5m																																																									
> SIGHT?	YES	NO																																																								
> Measuring.....																																																										
HR:	142° 23' 59"																																																									
HD:	15.8m																																																									
VD:	10.3m																																																									
NEW	---	---																																																								
CALC																																																										
Z COORD. SETTING																																																										
Z	12.345m																																																									
dZ	0.000m																																																									
---	---	BS SET																																																								
BACK SIGHT																																																										
HR:	180° 00' 00"																																																									
> Sight?	YES	NO																																																								
PROGRAM	1/2																																																									
F1: REM																																																										
F2: MLM																																																										
F3: Z COORD																																																										
<p>※1) Press the [F1](NEW) key to measure more points to improve precision, repeat the steps from ② to ⑤ .</p> <p>※2) Pressing the [F3] key, the display will be changed alternately.</p>																																																										

9.4 Area Measurement

This mode calculates the area of a closed figure.

There are two area calculation methods as follows.

1) Area Calculation from Coordinate data file

2) Area Calculation from Measured data

- Area is not calculated correctly if enclosed lines cross each other.
- It is impossible to calculate what a mix of coordinate file data and measured data.
- If the coordinate data file does not exist, the area calculation from measured data is done automatically.
- The numbers of points used to calculate are not limited.

9.4.1 Area Calculation from Coordinate Data File

Operating procedure	Operation	Display
① Enter PROGRAMS menu and press [F4] to enter page2.		<div style="border: 1px solid black; padding: 5px;"> PROGRAMS 2/2 F1: AREA F2: POINT TO LINE F3: NEW POINT P ↓ </div>
② Press the [F1] (AREA) key.	[F1]	<div style="border: 1px solid black; padding: 5px;"> AREA F1: KNOWN DATA F2: MEASURE </div>
③ Press [F1] (KNOWN DATA) key	[F1]	
④ Press the [F1] (INPUT) key and enter the file name. Initial display will be shown. The top of the file data is set as the first point of area automatically.	[F1] Enter the File name [F4]	<div style="border: 1px solid black; padding: 5px;"> SELECT A CFILE FN:FY_ INPT LIST --- ENT </div>

<p>⑤ Press the [F4](NEXT) key. ※1) , ※2) The top of the file data (F001) will be set and the second point number will be shown.</p> <p>⑥ Repeat pressing the [F4] (NEXT) key to set required number of points.</p> <p>When 3 or more points are set, the area surrounded by the points is calculated and the result will be shown. ※3)</p>	[F4]	<table border="1" style="width: 100%; border-collapse: collapse;"> <tr> <td style="padding: 5px;">AREA</td> <td style="text-align: right; padding: 5px;">0000</td> </tr> <tr> <td></td> <td style="text-align: right; padding: 5px;">m.sq</td> </tr> <tr> <td colspan="2" style="padding: 5px;">NEXT PT:F001</td> </tr> <tr> <td style="padding: 5px;">PT CALL UNIT NEXT</td> <td></td> </tr> </table> <table border="1" style="width: 100%; border-collapse: collapse;"> <tr> <td style="padding: 5px;">AREA</td> <td style="text-align: right; padding: 5px;">0001</td> </tr> <tr> <td></td> <td style="text-align: right; padding: 5px;">m.sq</td> </tr> <tr> <td colspan="2" style="padding: 5px;">NEXT PT:F002</td> </tr> <tr> <td style="padding: 5px;">PT CALL UNIT NEXT</td> <td></td> </tr> </table> <table border="1" style="width: 100%; border-collapse: collapse;"> <tr> <td style="padding: 5px;">AREA</td> <td style="text-align: right; padding: 5px;">0003</td> </tr> <tr> <td style="text-align: center; padding: 5px;">25.650</td> <td style="text-align: right; padding: 5px;">m.sq</td> </tr> <tr> <td colspan="2" style="padding: 5px;">NEXT PT:F004</td> </tr> <tr> <td style="padding: 5px;">PT CALL UNIT NEXT</td> <td></td> </tr> </table>	AREA	0000		m.sq	NEXT PT:F001		PT CALL UNIT NEXT		AREA	0001		m.sq	NEXT PT:F002		PT CALL UNIT NEXT		AREA	0003	25.650	m.sq	NEXT PT:F004		PT CALL UNIT NEXT	
AREA	0000																									
	m.sq																									
NEXT PT:F001																										
PT CALL UNIT NEXT																										
AREA	0001																									
	m.sq																									
NEXT PT:F002																										
PT CALL UNIT NEXT																										
AREA	0003																									
25.650	m.sq																									
NEXT PT:F004																										
PT CALL UNIT NEXT																										

- ※1) To set specify point, press the [F1](PT) key.
- ※2) To show the list of the coordinate data in the file, press the [F2](CALL) key.
- ※3) Every time press the [F3](UNIT) key to switch area unit.

9.4.2 Area Calculation from measured data

Operating procedure	Operation	Display											
<p>① Enter PROGRAMS menu and press [F4] to enter page2.</p> <p>② Press the [F1](AREA) key.</p>	[F1]	<table border="1" style="width: 100%; border-collapse: collapse;"> <tr> <td style="padding: 5px;">PROGRAMS</td> <td style="text-align: right; padding: 5px;">2/2</td> </tr> <tr> <td colspan="2" style="padding: 5px;">F1: AREA</td> </tr> <tr> <td colspan="2" style="padding: 5px;">F2: POINT TO LINE</td> </tr> <tr> <td colspan="2" style="padding: 5px;">F3: NEW POINT P ↓</td> </tr> </table> <table border="1" style="width: 100%; border-collapse: collapse;"> <tr> <td style="padding: 5px;">AREA</td> </tr> <tr> <td style="padding: 5px;">F1: KNOWN DATA</td> </tr> <tr> <td style="padding: 5px;">F2: MEASURE</td> </tr> </table>	PROGRAMS	2/2	F1: AREA		F2: POINT TO LINE		F3: NEW POINT P ↓		AREA	F1: KNOWN DATA	F2: MEASURE
PROGRAMS	2/2												
F1: AREA													
F2: POINT TO LINE													
F3: NEW POINT P ↓													
AREA													
F1: KNOWN DATA													
F2: MEASURE													

9.5 Point to Line

This mode is used to obtain the relative coordinate data from the coordinate system: origin point A (0, 0, 0) and the line AB as N axis.

Place the 2 prisms at the points A and B on the line, and place the instrument at unknown point C. After measuring the 2 Prisms, the coordinate data and the direction angle of the instrument will be calculated and restored.

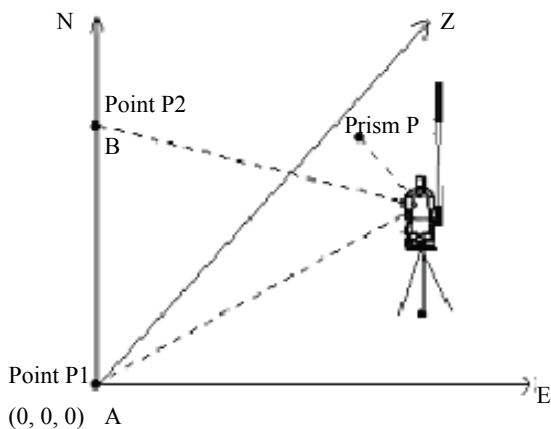

Operating procedure	Operation	Display
<p>① Make sure the displaying is in Program menu on page 2.</p> <p>② Press the [F2] (POINT TO LINE) key.</p> <p>③ Enter instrument height Press the [F4] key to confirm.</p>	<p>[F2]</p> <p>Enter INS.HT [F4]</p>	<div style="border: 1px solid black; padding: 5px; margin-bottom: 5px;"> <p>PROGRAM 2/2</p> <p>F1: AREA</p> <p>F2: POINT TO LINE</p> <p>F3: NEW POINT</p> </div> <div style="border: 1px solid black; padding: 5px;"> <p>INSTRUMENT</p> <p>HEIGHT INPUT</p> <p>Ins.Hi= 1.750_ m</p> <p>--- --- CLR ENT</p> </div>

<p>④Enter the reflector height of Point A, [F4] (ENT) to confirm.</p> <p>⑤Collimate Point A(P1), press the [F3] to measure.</p>	<p>Enter Ref.Hr [F4]</p> <p>[F3]</p>	<div data-bbox="578 139 896 296"> <p>REF HT INPUT</p> <p>Ref..Hr 0.000m</p> <p>--- --- CLR ENT</p> </div> <div data-bbox="578 313 896 470"> <p>POINT TO LINE</p> <p>MEAS. P1</p> <p>HD: m</p> <p>>SIGHT? YES NO</p> </div> <div data-bbox="578 486 896 644"> <p>POINT TO LINE</p> <p>MEAS. P1</p> <p>HD:* 15.632 m</p> <p><Measuring></p> </div>
<p>⑥Enter reflector height of point B. Press the [F4] key to confirm</p> <p>⑦Collimate Point B (P2), press the [F3] to measure.</p> <p>⑧The measured results will be shown. The coordinate data and direction angle of the instrument are calculated and restored. The result (the distance between A and B) will be displayed.</p>	<p>Enter R.HT [F4]</p> <p>Collimate A [F3]</p>	<div data-bbox="578 660 896 817"> <p>REF HT INPUT</p> <p>Ref.Hr=2.500_ m</p> <p>--- --- CLR ENT</p> </div> <div data-bbox="578 834 896 991"> <p>POINT TO LINE</p> <p>MEAS. P2</p> <p>HD: m</p> <p>>SIGHT? YES NO</p> </div> <div data-bbox="578 1007 896 1164"> <p>POINT TO LINE</p> <p>MEAS. P1</p> <p>HD* 78.840 m</p> <p>< Measuring></p> </div> <div data-bbox="578 1181 896 1218"> <p>< Complete></p> </div> <div data-bbox="578 1234 896 1391"> <p>DIST. (P1-P2) 1/2</p> <p>dHD: 8.080m</p> <p>dVD: 0.080m</p> <p>NEZ S.CO --- NP</p> </div>

9.6 Setting a new point

New point is required for example when a layout point cannot be sighted from existing control point.

9.6.1 Side short method

Set up the instrument at a known point, and measure the coordinate of the new points by the side short method.

Operating procedure	Operation	Display
<p>① Make sure the displaying is in Program menu on page 2.</p> <p>② Press [F3](NEW POINT) key.</p> <p>③ Press [F1](SIDE SHORT) key.</p> <p>④ Press [F2](LIST) key to display the list of coordinate data file. ※1)</p> <p>⑤ Scroll file list by pressing [▲] key or [▼] key and select a file to use. ※2)</p>	[F3]	<pre>PROGRAM 2/2 F1: AREA F2: POINT TO LINE F3: NEW POINT</pre>
	[F1]	<pre>NEW POINT F1: SIDE SHORT F2: RESECTION</pre>
	[F1]	<pre>SELECT A FILE FN: INPT LIST --- ENT</pre>
	[F2]	<pre>>&1 /C0002 1SV /C0000 TOP LAST SRCH ENT</pre>
	[▲] or [▼]	<pre>&1 /C0002 >1SV /C0140 S /C0000 TOP LAST SRCH ENT</pre>

<p>⑥ Press the[F4](ENT) key. The file will be set.</p> <p>⑦ Press the[F1] key , and enter the new point name PT#. Press the [F4] key.</p> <p>⑧ Enter R.HT in the same way.</p> <p>⑨ Collimate the new point, and press the [F3](YES) key to start measure distance.</p> <p>⑩ Press [F3](YES) key. The coordinate value is stored into COORD.DATA.file The input menu for next new point is displayed. PT# is automatically incremented</p>	<p>[F4]</p> <p>[F1] Enter</p> <p>PT# [F4]</p> <p>Enter</p> <p>Ref.Hr [F4]</p> <p>[F3]</p> <p>[F3]</p>	<div style="border: 1px solid black; padding: 5px; margin-bottom: 5px;"> SIDE SHOT PT#=F125_ NUM SPC CLR ENT </div> <div style="border: 1px solid black; padding: 5px; margin-bottom: 5px;"> REF HT INPUT Ref.Hr 0.000 m --- --- CLR ENT </div> <div style="border: 1px solid black; padding: 5px; margin-bottom: 5px;"> REFLECTOR HEIGHT INPUT Ref. 1.000 m >Sight? YES NO </div> <div style="border: 1px solid black; padding: 5px; margin-bottom: 5px;"> HR: 12° 34' 56" HD* < m VD: m >Measuring... </div> <div style="border: 1px solid black; padding: 5px; margin-bottom: 5px; text-align: center;"> < Complete > </div> <div style="border: 1px solid black; padding: 5px; margin-bottom: 5px;"> N: 56.287m E: 986.321 m Z: 123.345 m >REC? [YES] [NO] </div> <div style="border: 1px solid black; padding: 5px;"> SIDE SHOT PT#: F126 INPT SCRH --- ENT </div>
<p>※1) Press [F1](INPT) key and enter a file name.</p> <p>※2) The coordinate data can be searched by press [F3] (SRCH) key.</p>		

9.6.2 Resection method

Set up the instrument at a new point, and calculate the coordinate of the new point using the coordinate data of up to five known points and the measurements made to these points.

By following observation, resection is possible:

*Resection by distance measurement: 2 or more known points must be measured.

* Resection by angle measurement only: 3 or more points must be measured

NOTE: the new point can not be on the circum circle formed by the known points; otherwise the coordinate of new point is not correct.

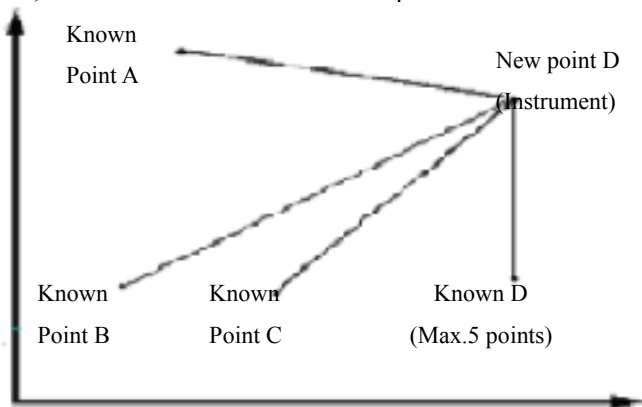

Operating procedure	Operation	Display
① Make sure the displaying is in Program menu on page 2.	[F3]	PROGRAM 2/2 F1: AREA F2: POINT TO LINE F3: NEW POINT
② Press [F3] (NEW POINT) key.		NEW POINT F1: SIDE SHORT F2: RESECTION
③ Press [F2] (RESECTION)		

<p>key.</p> <p>④ Select a coordinate file for known points.</p> <p>⑤ Enter the new point number. Press[F4] key. ※1</p> <p>⑥ Enter the instrument height. Press [F4] key.</p> <p>⑦ Press[F1(INPT)]key and enter the known point 1. ※2</p> <p>⑧ Press F3(YES) to confirm the coordinate for point 1.</p> <p>⑨ Enter reflector height. Press [F4] key.</p> <p>⑩ Collimate the first known point 1, and press[F3] or [F4]key to select measuring mode. Measuring starts.</p> <p>(11)The second known point B is waiting to confirm, entering display will be shown.</p>	<p>[F2]</p> <p>PT# [F4] [F4]</p> <p>INS.HT [F4]</p> <p>[F1] PT#</p> <p>[F3]</p> <p>R. HT [F4]</p>	<pre> SKLECT A CFILE FN=FOIFMA_ ALPH SPC CLR ENT NEW POINT PT#:45 INPT SRCH SKIP ENT INSTRUMENT HEIGHT INPUT Ins.Hi=1.500_ m --- --- CLR ENT N001# PT# INPT LIST NEZ ENT N: 99.925m E: 56.369m Z: 9.563m REC? [YES][NO] REF HT INPUT Ref.Hr=1.500_ m --- --- CLR ENT REF HT INPUT Ref.Hr=1.500_ m >SIGHT? ANG DIST </pre>
---	---	---

<p>(12) Same as procedure ⑤ - ⑩ proceed to the second known point 2.</p> <p>When two points have been measured, the RESIDUAL ERROR will be calculated. ※3)</p> <p>(13) Select GRID FACTOR for calculation of RESIDUAL ERROR by pressing [F1] or [F2] key. ※3)</p> <p>Example: [F1]</p> <p>(14) Press the [F1](NEXT) key to measure other points.</p> <p>Maximum five points can be measured.</p> <p>(15) Same as procedure ⑤-⑩ proceed to the known point 3.</p> <p>(16) The measured value is displayed. Press the [F4](CALC) key. Standard error will be shown.</p> <p>(17) Press the [F2](NP) key.</p> <p>Standard errors of each coordinate will be shown.</p> <p>The display will be changed alternately by pressing [F2] key.</p> <p>(18) Press the [F4](NEZ) key.</p> <p>Coordinate data of the new point will be shown.</p>		<div data-bbox="586 142 911 301"> <p>N002# PT#</p> <p>INPT LIST NEZ ENT</p> </div> <div data-bbox="586 365 911 523"> <p>SET GRID FACTOR F1:USE LAST DATA F2:CALC MEASDATA</p> </div> <div data-bbox="586 543 911 701"> <p>RESIDUAL ERROR dHD= 0.002m dZ = 0.003m NEXT --- G.F. CALC</p> </div> <div data-bbox="586 721 911 880"> <p>HR: 1° 23' 45" HD: 1.234 m VD: 0.001 m NEXT --- --- CALC</p> </div> <div data-bbox="586 899 911 1058"> <p>Standard Dev =2.01sec.</p> <p>--- NP --- NEZ</p> </div> <div data-bbox="586 1077 911 1236"> <p>SD(n) = 1.234m SD(e) = 0.001m SD(z) = 0.000m -- NP --- NEZ</p> </div> <div data-bbox="586 1255 911 1399"> <p>N: 1.234m E: 0.001m Z: 0.000m REC? [YES] [NO]</p> </div>
---	--	--

10. Memory Manager Mode

The following items for internal memory are available in this mode.

- 1) FILE STATUS: Checking the number of files or data in memory.
- 2) SEAECH: Searching and view point of memory.
- 3) FILE MAINTAN: Deleting files /Editing file name
- 4) COORD.INPUT: Inputting coordinate data to memory by keyboard.
- 5) DELETE COORD: Deleting coordinate data from memory.
- 6) PCODE INPUT: Inputting PCODE data into memory by keyboard.
- 7) COMM.PARAM.

SEND DATA: Sending measured data or coordinate data from instrument internal memory to other equipments.

RECEIVE DATA: Uploading measured data or coordinate data to total station internal memory.

COMM PARAMENT: Communication parameters setting

8) INITIALIZE: Initializing internal memory, all the file and data will be cleared.

9) U Function: Enter the connecting interface between TS650 and PC by USB port

10.1 Enter Memory Manager Mode

Operating procedure	Operation	Display
① Press the [MENU] key to enter menu mode.	[MENU]	<div style="border: 1px solid black; padding: 5px;"> MENU 1/2 F1: DATA COLLECT F2: LAYOUT F3: MEMORY MGR </div>
② Press the [F3](MEMORY MGR.) key to enter memory manager mode. Press the [▲] or [▼] to turn page.	[F3]	<div style="border: 1px solid black; padding: 5px;"> MEMORY MGR. 1/3 F1: FILE STATUS F2: SEARCH F3: FILE MAINTAN P ↓ </div>

10.2 Display Internal Memory Status

Operating procedure	Operation	Display
①Make sure the displaying in Memory Manager mode on page1. ②Press the [F1] (FILE STATUS) key, the total number of stored Measured data files and Coordinate data files are shown. ③Press the [F4] (P) key to display the page 2, the total number of stored measured data and coordinate data are shown ※1)	[F1]	<pre> MEMORY MGR. 1/3 F1: FILE STATUS F2: SEARCH F3: FILE MAINTAN </pre>
	[F4]	<pre> FILE STATUS 1/2 MEAS. FILE : 4 COORD. FILE : 7 [.....] P ↓ </pre>
※1) Press the [F4] key to change the displaying status between files or data.		

10.3 Searching data

MEAS.DATA: Measured data.

COORD.DATA: known coordinate data for layout or station setting

PCODE Library: The data which was registered with a number from 0 to 49.

10.3.1 Measured data searching

Operating procedure	Operation	Display
①Make sure the displaying mode in Memory Manager on page 1.		<pre> MEMORY MGR. 1/3 F1: FILE STATUS F2: SEARCH F3: FILE MAINTAN </pre>

<p>② Press the [F2] (SEARCH) key.</p> <p>③ Press the [F1] (MEAS. DATA) key.</p> <p>④ Press the [F1] key to input file name. Press the [F4] key to confirm.</p> <p>⑤ Press the [F3](PT# DATA) key. ※1)</p> <p>⑥ Input PT#, press the [F4] to confirm, the point data will display in details.</p> <p>⑦ Press the [F4] key to turn page, other information of this point are shown. ※2) ※3)</p>	<p>[F2]</p> <p>[F1]</p> <p>[F1]</p> <p>Input file name</p> <p>[F4]</p> <p>[F3]</p> <p>Input PT#</p> <p>[F4]</p> <p>[F4]</p>	<table border="1"> <tr> <td>SEARCH F1: MEAS. DATA F2: COORD. DATA F3: PCODE LIB</td> </tr> <tr> <td>SELECT A FILE FN:1 INPT LIST --- ENT</td> </tr> <tr> <td>MEAS. DATA SEARCH F1: FIRST DATA F2: LAST DATA F3: PT# DATA</td> </tr> <tr> <td>PT# DATA SEARCH PT#=_ NUM SPC CLR ENT</td> </tr> <tr> <td>PT#]1 1/3 N] 3713804.5836m E] 389849.825m Z] 959.514m ↓</td> </tr> <tr> <td>PT#]1 3/3 PCODE] Ref.Hr] 1.680m EDIT ↓</td> </tr> </table>	SEARCH F1: MEAS. DATA F2: COORD. DATA F3: PCODE LIB	SELECT A FILE FN:1 INPT LIST --- ENT	MEAS. DATA SEARCH F1: FIRST DATA F2: LAST DATA F3: PT# DATA	PT# DATA SEARCH PT#=_ NUM SPC CLR ENT	PT#]1 1/3 N] 3713804.5836m E] 389849.825m Z] 959.514m ↓	PT#]1 3/3 PCODE] Ref.Hr] 1.680m EDIT ↓
SEARCH F1: MEAS. DATA F2: COORD. DATA F3: PCODE LIB								
SELECT A FILE FN:1 INPT LIST --- ENT								
MEAS. DATA SEARCH F1: FIRST DATA F2: LAST DATA F3: PT# DATA								
PT# DATA SEARCH PT#=_ NUM SPC CLR ENT								
PT#]1 1/3 N] 3713804.5836m E] 389849.825m Z] 959.514m ↓								
PT#]1 3/3 PCODE] Ref.Hr] 1.680m EDIT ↓								
<p>※1) Press the [F1] key ,the first point data will be shown, press the [F2] key, the last point data will be shown.</p> <p>※2) Press the [▲] or [▼] key to display previous or next point data.</p> <p>※3) Press F1(EDIT) to edit the PT#, PCODE, or target height of this point.</p>								

10.3.2 Coordinate Data Searching

Operating procedure	Operation	Display
① Make sure the displaying is in Memory Manager mode on page 1.		<pre>MEMORY MGR. 1/3 F1: FILE STATUS F2: SEARCH F3: FILE MAINTAN</pre>
② Press the [F2] key.	[F2]	<pre>SEARCH F1: MEAS. DATA F2: COORD. DATA F3: PCODE LIB</pre>
③ Press the [F2] (COORDDATA) key.	[F2]	<pre>SELECT A FILE FN: INPT LIST --- ENT</pre>
④ Press the [F1] key to input file name. Press the [F4] key to confirm.	[F1] Input file name	<pre>COORDDATA SEARCH F1: FIRST DATA F2: LAST DATA F3: PT# DATA</pre>
⑤ Press the [F3] (PT# DATA) key. ※1)	[F4] [F3]	<pre>PT# DATA SEARCH PT#=8_ INPT SPC CLR ENT</pre>
⑥ Press the [F1] key to input PT#, press the [F4] to confirm, this point data will display	[F1] Input PT#	<pre>PT#]8 1/2 N] 3725350.730m E] 602484.036m Z] 945.646m ↓</pre>
⑦ Press the [F4] key, other information of this point are shown.※2)	[F4]	<p>※1) Press the [F1] key, the first point data will be shown, press the [F2] key, the last point data will be shown.</p> <p>※2) Press the [▲] or [▼] key to display previous point data or next point data.</p>

10.3.3 PCODE Library Searching

Example searching: Number searching

Operating procedure	Operation	Display
①Make sure the displaying is in Memory Manager mode on page 1.		<pre> MEMORY MGR. 1/3 F1: FILE STATUS F2: SEARCH F3: FILE MAINTAN </pre>
②Press the [F2] key.	[F2]	<pre> SEARCH F1: MEAS. DATA F2: COORD. DATA F3: PCODE LIB </pre>
③Press the [F3] (PCODE LIB) key.	[F3]	<pre> PCODEDATA SEARCH F1: FIRST DATA F2: LAST DATA F3: NO. SEARCH </pre>
④Press the [F3](PT# DATA) key.※1)	[F3]	<pre> NO. SEARCH NO.=10_ --- --- CLR ENT </pre>
⑤Enter number. Press the [F4] key to confirm.※2)※3)	[F1] Input number [F4]	<pre> > 009 : SYG 010 : FOIF 011 : GPS EDIT --- CLR --- </pre>
<p>※1) Press the [F1] key ,the first point data will be shown, press the [F2] key, the last point data will be shown.</p> <p>※2) Press the [▲] or [▼] key to display the previous or next PCODE, press the [F1] key to edit it, and press the [F3] key to delete this PCODE.</p> <p>※3) Press [F1](Edit) to edit this PCODE. Press [F3] (CLR) to delete this PCODE.</p>		

10.4 File Maintenance

In this menu, the following items are available: Renaming file name, Searching data in a file and Deleting files, special symbols will be shown.

```
>@FOIF_001 /C0008
 *FOIF_002 /C0022
   FOIF_003 /M0108
REN  SRCH DEL  ---
```

(1) File discrimination mark (*, @).

The mark (* or @) placed ahead file name indicates the file status.

For measured data file:

“*” means selected file for recording the measured data

For coordinate data file:

“*” means selected file for LAYOUT mode.

“@” means selected coordinate file for DATA COLLECT mode.

(2) Data type discrimination character (M, C)

Data type discrimination character (M, C) placed before four figures indicate the type of data.

“M” means measured data

“C” means known coordinate data

(3) Four numbers following “M” or “C” means the recorded point quantity in the file.

(4) This is a PCODE library in the memory. And it can record 50 PCODE in the library; the ID number of PCODE can be set from 01 to 50 freely.

10.4.1 Rename a file

Operating procedure	Operation	Display
①Make sure the displaying is in Memory Manager mode on page 1.		<pre> MEMORY MGR. 1/3 F1: FILE STATUS F2: SEARCH F3: FILE MAINTAN ↓ </pre>
②Press the [F3] (FILE MAINTAL) key, the files in memory will be shown.	[F3]	<pre> >*1 /M0013 1SV /M0056 REN SRCH DEL --- </pre>
③Press the [F1] key to input the new file name, and press the F4 to confirm.	[F1] Input [F4]	<pre> >=FOIF_ /M0013 1SV /M0056 REN SRCH DEL --- </pre>

10.4.2 Deleting a File

Operating procedure	Operation	Display
①In the files displaying mode as 10.4.1-②, Selecting a file by pressing [▼] key or [▲] key, press the [F3](DEL) key to delete.	[F3]	<pre> >FOIF /M0013 1SV /M0056 >DEL? [NO] [YES] </pre>
②Confirm the deleting, and press the [F4] (YES) key.	[F4]	<pre> >1SV /M0056 REN SRCH DEL --- </pre>

10.4.3 Searching Data in a File

Operating procedure	Operation	Display
<p>①In the files displaying mode as above procedure 10.4.1-②</p> <p>②Selecting a file by pressing [▼] key or [▲] key, press the [F2](SRCH) key</p> <p>③Select searching method by pressing the [F1] to [F3] key.※1)</p>	[F2]	<pre>>1 /M0003 1SV /M0000 REN SRCH DEL ---</pre> <pre>> 1SV /M0000 REN SRCH DEL ---</pre> <pre>SEARCH [1SV] F1: FIRST DATA F2: LAST DATA F3: PT# DATA</pre>
※1) The first line displays file's name.		

10.5 Coordinate Data Direct Key input

Coordinate data for the layout point or control point can be input directly from keyboard. This data can be stored into a file in internal memory.

Operating procedure	Operation	Display
<p>①Make sure the displaying is in Memory Manager mode on page 2.</p> <p>②Press the [F1] key (COORD INPUT).</p>	[F1]	<pre>MEMORY MGR. 2/3 F1: COORD INPUT F2: DELETE COORD F3: PCODE INPUT</pre>
	[F1]	<pre>SELECT A FILE FN:1SV INPT LIST --- ENT</pre>

<p>③ Press the [F1] key to input File name you want to input. Press the [F4] to confirm.</p> <p>④ Press the [F1] [INPT] key to input PT#. Press the [F4] to confirm.</p> <p>⑤ Input N coordinate data, press [F4] to confirm and move to E coordinate inputting status. After input Z, enter PCODE inputting menu,</p> <p>⑥ Input PCODE, press F4, “complete” will display. Then next input display is shown. Point number (PT#) can increase automatically.</p> <p>⑦ Press the [ESC] to return.</p>	<p>Input file name [F4]</p> <p>[F1] Input PT# [F4]</p> <p>[F1] Input Coord data [F4]</p>	<div data-bbox="560 139 881 298" style="border: 1px solid black; padding: 5px;"> <p>SELECT A CFILE FN=FOIF_ ALPH SPC CLR ENT</p> </div> <div data-bbox="560 313 881 471" style="border: 1px solid black; padding: 5px;"> <p>COORD DATA INPUT PT#=1_ INPT LIST --- ENT</p> </div> <div data-bbox="560 486 881 645" style="border: 1px solid black; padding: 5px;"> <p>N=0.000 _ m E 0.000m Z 0.000m INPT --- ---</p> </div> <div data-bbox="560 660 881 819" style="border: 1px solid black; padding: 5px;"> <p>COORD DATA INPUT CODE: INPT LIST ---- ENT</p> </div> <div data-bbox="560 834 881 992" style="border: 1px solid black; padding: 5px;"> <p>COORD DATA INPUT PT#:2 INPT LIST --- ENT</p> </div>
--	--	---

10.6 Delete a Coordinate Data from a File

Operating procedure	Operation	Display
① Make sure the displaying is in Memory Manager mode on page 1.		<pre> MEMORY MGR. 1/3 F1: FILE STATUS F2: SEARCH F3: FILE MAINTAN P ↓ </pre>
② Press the [F4] key to display page 2.	[EDM]	<pre> MEMORY MGR. 2/3 F1: COORD INOUT F2: DELETE COORD F3: PCODE INPUT </pre>
③ Press the [F2] key. (DELETE COORD)	[F2]	
④ Press the [F1] (INPT) key and enter File Name. Press the [F4] key to confirm.	[F1] INPT FILE [F4]	<pre> SELECT A FILE FN:=FOIF_ INPT LIST --- ENT </pre>
⑤ Press the [F1] key and enter Point Number (PT#), press [F4] key to confirm.	[F1] INPUT PT# [F4]	<pre> DELETE COORD PT#:=15_ INPT LIST --- ENT </pre>
⑥ The instrument will ask you to confirm, press [F3] to delete the selected point, or press [F4] the selected point can not be deleted.	[F3]	<pre> N: 100.000 m E: 100.000 m Z: 100.000 m >DEL? [YES][NO] </pre>

10.7 Editing PCODE Library

PCODE data can be entered into PCODE Library in this menu. A PCODE is linked with a number of 1 to 50. PCODE can be also edited in DATA COLLECT mode.

Operating procedure	Operation	Display
①Make sure the displaying is in Memory Manager mode on page 1.		<pre> MEMORY MGR. 1/3 F1: FILE STATUS F2: SEARCH F3: FILE MAINTAN </pre>
②Press the [▼] key once to display page 2.	[▼]	<pre> MEMORY MGR. 2/3 F1: COORD INPUT F2: DELETE COORD F3: PCODE INPUT </pre>
③Press the [F3] (PCODE INPUT) key.	[F3]	<pre> >001: 12345678 002: SVYJMPADG EDIT --- CLR --- </pre>
④By pressing the [▲] or [▼] keys to move the cursor.		<pre> 001: 12345678 >002: SVYJMPADG 003: 1234567890 EDIT --- CLR --- </pre>
⑤Press the [F1] (EDIT) key and input PCODE at current position of cursor, press the [F4] key to confirm.	[F1] [F4]	<pre> 001: 12345678 >002= SVYJMPADG_ 003: 1234567890 ALPH SPC CLR ENT </pre>

10.8 Data Transfer by serial port

The data in internal memory can be transferred to PC by RS232C serial cable D3-1000(Optional) directly. Before sending data, please connect instrument and PC correctly with RS-232C cable, and the communication settings of instrument are same as PC's settings.

The data in instrument memory can be downloading to PC, also the data can be uploaded from PC to instrument memory.



D3-1000 serial cable (Optional)

10.8.1 Sending data

Example: sending a measured data file.

Operating procedure	Operation	Display
① Make sure the displaying is in Memory Manager mode on page 3.		MEMORY MGR. 3/3 F1: COMM.PARAM. F2: INITIALIZE F3: U Function P ↓
② Press [F1] (COMM.PARA M) key.	[F1]	Data Com F1:GTS F2:SSS
③ Select data format. F1: GTS: Normal format F2: SSS: With code.	[F1]	Data Com. F1: SEND DATA F2: RECEIVE DATA F3: COMM PARAMENT
④ Press the [F1] (SEND DATA) key.	[F1]	

<p>Press [F1] (MEAS.DATA) key.</p> <p>⑤ Press the [F1] key to input File Name, press the [F4] key to confirm.</p> <p>⑥ After the receiving equipment (PC) is ready, press the [F3] (YES) to confirm, the sent point quantity will display in real-time, press F4 (STOP) to stop data sending.</p>	<p>[F1]</p> <p>[F1] Input File Data</p> <p>[F4]</p> <p>[F3]</p>	<div data-bbox="586 123 903 278" style="border: 1px solid black; padding: 5px;"> SEND DATA F1: MEAS. DATA F2: COORD.DATA F3: PCODE DATA </div> <div data-bbox="586 308 903 464" style="border: 1px solid black; padding: 5px;"> SELECT A FILE FN=FOIF_ ALPH SPC CLR ENT </div> <div data-bbox="586 516 903 672" style="border: 1px solid black; padding: 5px;"> SEND MEAS. DATA >OK? --- --- YES NO </div> <div data-bbox="586 709 903 865" style="border: 1px solid black; padding: 5px;"> SEND MEAS. DATA 88 --- --- --- STOP </div>
---	---	--

10.8.2 Loading data

Example: Loading a coordinate data file to TS650 memory

Operating procedure	Operation	Display
<p>① Following steps ① to ③ of “10.8.1 Sending data”.</p> <p>② Press the [F2] (RECEIVE DATA).</p> <p>③ Press [F1] (COORDDATA) key.</p>	<p>[F2]</p> <p>[F1]</p>	<div data-bbox="586 1114 903 1270" style="border: 1px solid black; padding: 5px;"> Data Com. F1: SEND DATA F2: RECEIVE DATA F3: COMM PARAMENT </div>

<p>④ Press the [F1] key to input File Name, press the [F4] key to confirm.</p> <p>⑤ If the cable connection between TS650 and PC is ready, press F3(YES) to confirm.</p> <p>⑥ Operate on the PC software, begin sending data from PC to TS650. Press F4 (STOP) to stop data receiving.</p>	<p>[F1] Input File Data [F4]</p> <p>[F3]</p>	<div data-bbox="640 179 959 338" style="border: 1px solid black; padding: 5px;"> LOAD DATA F1: COORDDATA F2: PCODE LIB </div> <div data-bbox="640 357 959 516" style="border: 1px solid black; padding: 5px;"> COORD FILE NAME FN=FOIF_ ALPH SPC CLR ENT </div> <div data-bbox="640 568 959 727" style="border: 1px solid black; padding: 5px;"> LOAD DATA <Waiting Load !> --- --- --- STOP </div>
--	--	---

10.8.3 Setting parameter of data communications

Items of the Parameter

Item	Selecting item	Content
F1: Protocol	[ACK/NAK]/[NO]	Setting Protocol [ACK/NAK] or [NO] communication
F2: Baud rate	1200/2400/4800/ 9600/19200/38400	Setting transfer speed 1200/2400/4800/9600/19200 /38400 baud rate
F3: Char. / Parity	[7/EVEN]/ [7/ODD]/ [8/NON]	Setting data length and parity: [7bit, even], [7bit, odd], or [8bit,none]
F1: Stop Bits	1, 2	Setting Stop 1 bit or 2bits

10.9 Memory initialize

Delete all the files or clear the whole memory.

Example: Delete all the measured data files

Operating procedure	Operation	Display
<p>① Make sure the displaying is in Memory Manager mode on page 3.</p> <p>② Press [F2] (INITIALIZE) key.</p> <p>③ Select the option you can to clear.</p> <p>MEAS FILES, clear all measured files COORD FILES, clear all coordinate files PCODE FIELDS, clear all PCODEs Format, the whole memory will be clear.</p> <p>④ Press the [F3] (YES) key, all coordinate data files will be deleted. It returns to previous menu automatically.</p>	[F2]	<pre>MEMORY MGR. 3/3 F1: COMM.PARAM. F2: INITIALIZE F3: U Function P ↓</pre>
		[F2]
	[F3]	
		<pre>INITIALIZE F1:MEAS FILES F2:COORD FILES F3:PCODE FILES P ↓</pre>
<p>Warning: All the deleted files and data can not be restored.</p>		

10.10 Connect PC via USB port

For TS110 USB cable D30-2200 is standard data transfer cable, you can connect TS110 and PC by D30-2200 directly, no driver program need.

Of course if your TS110 equipped with USB port, you can use standard USB cable to connect TS110 with PC for data transferring.

The data transferring procedures are same for D30-2200 cable and standard USB cable.



Standard equipment

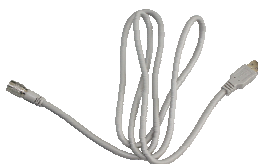

**D30-2200
USB cable**



→ Mini USB port
→ SD card slot

Optional equipment

Operating procedure	Operation	Display				
<p>①Make sure the displaying is in Memory Manager mode on page 3.</p> <p>②Press [F3] (U Function) key.</p> <p>③Connect instrument and PC via D30-2200 cable or standard USB cable, TS650 will display “U FUNCTION Press ESC exit”. ※1) It means the TS650 is connected with PC already. Press [ESC] to disconnect them, and the instrument back to previous menu.</p>	[F3]	<table border="1" style="width: 100%; border-collapse: collapse;"> <tr> <td style="padding: 5px;">MEMORY MGR. 3/3</td> </tr> <tr> <td style="padding: 5px;">F1: COMM.PARAM.</td> </tr> <tr> <td style="padding: 5px;">F2: INITIALIZE</td> </tr> <tr> <td style="padding: 5px;">F3: U Function P ↓</td> </tr> </table>	MEMORY MGR. 3/3	F1: COMM.PARAM.	F2: INITIALIZE	F3: U Function P ↓
	MEMORY MGR. 3/3					
	F1: COMM.PARAM.					
F2: INITIALIZE						
F3: U Function P ↓						
[F2]	<table border="1" style="width: 100%; border-collapse: collapse;"> <tr> <td style="padding: 5px;">U Function</td> </tr> <tr> <td style="padding: 5px;">Plug the USB</td> </tr> <tr> <td style="padding: 5px;">Press ESC exit</td> </tr> </table>	U Function	Plug the USB	Press ESC exit		
U Function						
Plug the USB						
Press ESC exit						
[ESC]	<table border="1" style="width: 100%; border-collapse: collapse;"> <tr> <td style="padding: 5px;">MEMORY MGR. 3/3</td> </tr> <tr> <td style="padding: 5px;">F1: COMM.PARAM.</td> </tr> <tr> <td style="padding: 5px;">F2: INITIALIZE</td> </tr> <tr> <td style="padding: 5px;">F3: U Function P ↓</td> </tr> </table>	MEMORY MGR. 3/3	F1: COMM.PARAM.	F2: INITIALIZE	F3: U Function P ↓	
MEMORY MGR. 3/3						
F1: COMM.PARAM.						
F2: INITIALIZE						
F3: U Function P ↓						

※1) After TS110 is connecting with PC, the data folder in memory will open automatically, with FOIFExchange software to view the data.



CINDEX



CODE



CORD



MEAS



MINDEX

10.11 Copy the data files from memory to SD card (Optional)



If you TS110 is equipped with SD card module, you can copy the data files from internal memory to SD card.

Example: Transferring all measured data files to SD card.

Operating procedure	Operation	Display
<p>①Enter Menu mode on page 3. Press [F3] (SD COPY) to enter copying menu.</p> <p>②Press [F1] (MEAS.DATA) key. The entire measured data file will be transferred from internal memory to SD card. At last back to previous menu automatically.</p>	[F3]	<div style="border: 1px solid black; padding: 5px;"> <p>MENU 3/3 F1: CONTRAST F2: COM MODE F3: SD COPY P ↓</p> </div>
		<div style="border: 1px solid black; padding: 5px;"> <p>SD COPY F1:MEAS.DATA F2:COORD.DATA F3: All Files</p> </div>
	<div style="border: 1px solid black; padding: 5px;"> <p>Copying.....</p> </div>	
	<div style="border: 1px solid black; padding: 5px;"> <p>MENU 3/3 F1: CONTRAST F2: COM MODE F3: SD COPY P ↓</p> </div>	

10.12 Connect TS110 with other device via Bluetooth (Optional)

If you TS110 is equipped with Bluetooth module, you can connect it with other device via wireless communication

Operating procedure	Operation	Display
<p>①Enter Menu mode on page 3.</p> <p>②Press [F2] (COM MODE) key.</p> <p>③Press [F2] (BLUE TOOTH), press [F4] to confirm.</p> <p>④Press [ESC] back to basic measurement mode. You will see the Bluetooth mark on the screen right.</p> <p>Now use you device to search the TS110 for communication.</p>	<p>[F2]</p> <p>[F2]</p> <p>[F4]</p> <p>[ESC]</p>	<div data-bbox="586 332 905 486"> <p>VZ: 81° 54' 21" HR: 157° 33' 58"  0SET HOLD HSET P1</p> </div> <div data-bbox="586 495 905 649"> <p>MENU 3/3 F1: CONTRAST F2: COM MODE F3: SD COPY P ↓</p> </div> <div data-bbox="586 658 905 822"> <p>Com Mode [F1:RS-232C] F2:BLUETOOTH ENT</p> </div> <div data-bbox="586 836 905 991"> <p>MENU 3/3 F1: CONTRAST F2: COM MODE F3: SD COPY P ↓</p> </div> <div data-bbox="586 1015 905 1193"> <p>VZ: 81° 54' 21" HR: 157° 33' 58"   0SET HOLD HSET P1</p> </div>

11. Instrument Settings

In the parameters menu 1, there are some normal used settings, they are normal used for measurement.

11.1 Items of instrument settings

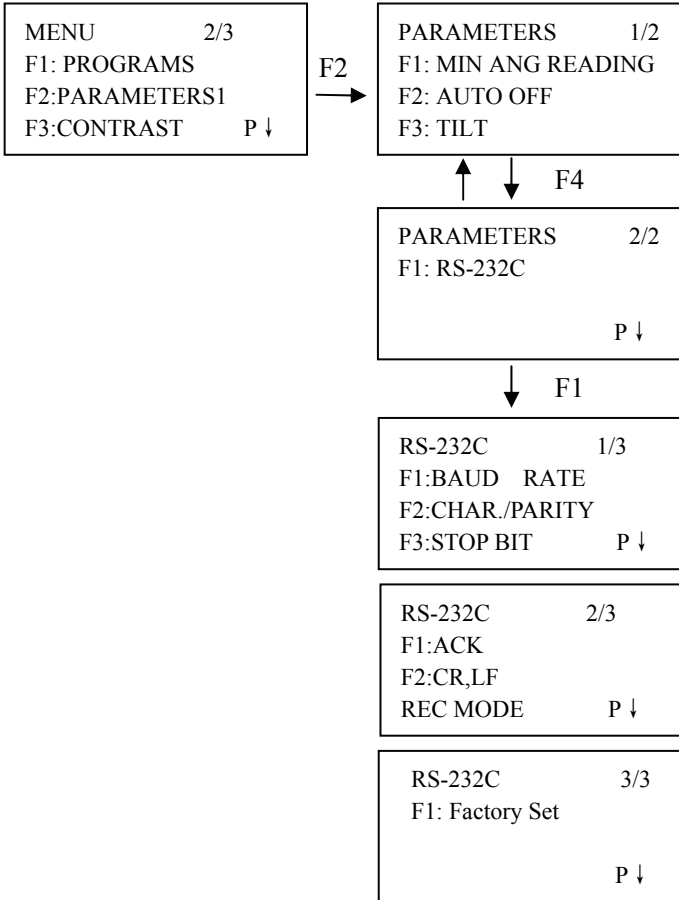

(* factory setting)

Menu Display	Optional	Content	
MIN ANG READING	1" /0.2mgon*	The min angle reading is 1" /0.2mgon	
	5" /1mgon	The min angle reading is 5" /1mgon	
	10" /2mgon	The min angle reading is 10" /2mgon	
AUTO OFF	10M/30M	After 10 or 30 minutes without any operation, power will auto-off	
	OFF *	auto-off isn't active	
TILT	OFF	The tilt sensor is OFF	
	ON *	The tilt sensor is ON	
RS-232C	BAUD RATE	1200* 2400 4800 9600 19200 38400	
	CHAR. /PARITY	7/EVEN	7 Data length, even parity
		7/ODD	7 Data length, odd parity
		8/NONE*	8 Data length, no parity
	STOP BIT	1 *	One stop bit
		2	Two stop bit
	ACK	Standard	Communication way: double-action
		Omitted *	Communication way: single-action
	CR,LF	ON	With carriage return
		OFF *	Without carriage return
REC MODE	REC-A*	Measuring and output measured data	
	REC-B	Output displayed data	
Factory Set		Recall factory setting	

11.2 Enter setting mode

Operating procedure	Operation	Display
<p>①Make sure the displaying is menu mode on page 2.</p> <p>②Press the [F2] (PARAMETERS) key.</p>	[F2]	PARAMETERS 1/2 F1: MIN ANG READING F2: AUTO OFF F3: TILT
		PARAMETERS 1 1/2 F1: MIN ANG READING F2: AUTO OFF F3: TILT

11.3 Setting procedures

Example: change the minimum reading from 1" to 5".

Operating procedure	Operation	Display
<p>①Make sure the displaying is PARAMETERS menu on page 1.</p> <p>②Press the [F1] key, the current setting will be shown in the“[]”.</p> <p>③Press the [F2](5") key, press the [F4] to confirm.</p>	[F1]	PARAMETERS 1/2 F1:MIN ANG READREADING F2: AUTO OFF F3:TILT P ↓
		MinANGLE [F1: 1"] F2: 5" F3: 10" ENT
		MinANGLE F1: 1" [F2: 5"] F3: 10" ENT

12. Selecting Mode

12.1 Items of selecting mode

The following modes are available

Menu	Items	Selecting item	Display
F1: Unit	F1:Temperature	°C/°F	Select the unit of temperature for atmospheric correction
	F2:Pressure	hPa/mmHg/in Hg/psi/ mbar	Select the unit of air pressure for atmospheric correction
	F3:ANGLE	DMS(360°)/ GON(400G)/ MIL(6400M)	Choose degree, gon or mil unit for measuring angle
	F1:Dist	M/Ft/Ftin	Choose measuring unit for distance meter, feet or feet and inch
	F2:Feet	US_feet/ IN_feet	Select the meter/feet conversion factor US SURVEY feet 1m=3.280833333333333ft INTERNATIONAL feet 1m=3.280839895013123ft
F2: Mode	F1:Power On Mode	Angle/Dist	Select to set the measurement mode for angle or distance when the power is turned on
	F2:Fine/Track	Fine/Tracking	Select Fine/Tracking mode in distance measurement mode, when the power is turned on
	F3:HD/SD	HD&VZ/SD	Specify which is displayed first, horizontal and vertical distance or slope distance, when the power is turned on

	F1:Z0/H0	VZ0/HA0	Choose the vertical angle reading from zenith or from level
F2: Mode	F2:NTIMES/ REPEAT	N TIMES/ REPEAT	Select the measurement mode for distance when the power is turned on
	F3:MEAS TIMES	0-99	Set N (number of times) for times of distance measurement. When setting number of times as 1, it is single measurement
	F1:NEZ/ENZ	NEZ/ENZ	Select a coordinate displaying order either NEZ or ENZ
	F2:Offset VA	Free /Hold	Select Vertical angle setting in the Angle Offset measurement mode. FREE: Vertical angle varies by the angle of the telescope. HOLD: Vertical angle is fixed even if the angle of the telescope changes.
	F3:ESC MODE	Collect/SO /Rec/OFF	You can select a function of the [ESC] key. DATA COLLECT/ LAYOUT: It is possible to enter data input mode (in DATA COLLECT) or Layout Menu from normal measuring mode directly. REC: While executing normal or offset measuring, the measuring data can be output. OFF: Returns to normal function

F2: Mode	F1:Coor Check	ON/OFF	Select coordinate displaying ON or OFF when setting a point
	F2:EDMOff Time	0-99	The time when EDM is cut off from distance measurement is completed can be changed. This function is effective for shortening time measuring time when distance measurement is started from distance measurement completing state. Default:3minutes) 0 :After completing distance measurement, EDM is cut off immediately. 1-99: EDM is cut off after 1~99 minutes.
	F3:Read Min	0.2mm/1mm	Select 1mm or 0.2mm for the minimum reading unit in the distance mode (FINE mode)
F3: Other	F1:HA Buzzer	ON/OFF	Specify whether the buzzer sounds or not for every horizontal angle 90°
	F2:Signal Buzzer	ON/OFF	Specify whether the buzzer sounds or not in the set audio mode.
	F3:K select	0.14/0.20/OFF	Set correction for refraction and earth curvature, efficient of refraction as ; K=0.14, K=0.20 or no correction

F3: Other	F1:Coor Rec	ON/OFF	It is possible to retain the coordinate of instrument point, the instrument height and prism height after power off.
	F2:Rec Type	REC-A/ REC-B	Select REC-A or REC-B for data output REC-A: The measurement is made again and this new data is output. REC-B: The data being displayed is output
	F3:CR,LF	ON/OFF	It is possible to output the data with carriage return and line feed.
	F1:NEZ Rec	Standard12/ WithMeas12	Select to record coordinates in standard or 11 digits with raw data
	F2:InputCoor Re	ON/OFF	In the layout mode or data collect mode, it is possible to record coordinates entered directly from the keyboard
	F3:ACK	Standard/Omitted	Set the procedure of the communication with external device. STANDARD: Normal procedure OMITTED: Even though the [ACK] is omitted from the external device, the data is sent again
	F1: GRID FACTOR	Use/Not Use	Select using GRID FACTOR in calculation of measurement data

F3: Other	F2:Cut Or Fill	Standard/Cut &Fill	In the layout mode, CUT & FILL can be displayed instead of dZ
	F3:Back Disp	ON/OFF	It is possible to output the data of echo back type
	F1:Contrast men	ON/OFF	When the instrument is turned ON, it is possible to display the screen which you can adjust contrast of the display and confirm the prism constant (PSM) and atmospheric correction value (PPM)
	F2:LANGUAGE	ENGLISH/ OTHER	Select the displaying language.
	F3:Key Buzzer	ON/OFF	Setting the key pressing buzzer ON/OFF

12.2 How to set selecting mode

<Example>: Setting unit in °F, NEZ MEMORY:ON

Operating procedure	Operation	Display
① While pressing F2 key, turn Power ON	F2 + Power on	PARAMENT 2 F1:UNIT F2:Mode F3:Other
②Press the [F1] key, the current setting will be shown in the“[]”.	[F1]	Unit 1/2 F1: Temperature F2: Pressure F3:Angle P ↓
③Press [F2](°F) key, and press[F4](ENTER) key.	[F2] [F4]	Temp. Unit [°C] °C °F ENT

Operating procedure	Operation	Display
④ Press [ESC] key. Returns to PARAMETERS 2 menu.	[ESC]	PARAMENT 2 F1:UNIT F2:Mode F3:Other
⑤ Press [F3] (OTHERS SET) key.	[F3]	Other 1/5 F1:HA Buzzer F2:Signal Buzzer F3:K Select P ↓
⑥ Press [F4] (P↓) key, to get the function in page 2.	[F4]	Other 2/5 F1:Coor Rec F2:Rec Type F3:CR,LF P ↓
⑦ Press [F1] key.	[F1]	Coor Rec [OFF] ON OFF [ENT]
⑧ Press [F1](ON) key, and press [F4] (ENTER) key. Returns to OTHERS SET menu. ⑨ Power off	[F1] [ENT]	Other 2/5 F1:Coor Rec F2:Rec Type F3:CR,LF P ↓

13. Check and adjustment

13.1 Checking and adjusting of instrument constant

Instrument constant means additive constant for distance measurement.

Normally, the instrument constant doesn't have error. It is recommended you measure and compare with an accurately measured baseline one consistent ground. If such a baseline is not available, establish your own base line over 20m and compare the data measured with the newly purchased instrument.

In case, the instrument setup, the prism, baseline precision, poor collimation, atmospheric correction, correction for refraction and earth curvature determine the inspection precision.

Also, when providing a base line indoor, the following procedure as shown below could be used to check the instrument constant.

(1) Provide point B on a straight line AC, which is almost level and about 100m long. Measure straight lines AB, AC and BC.

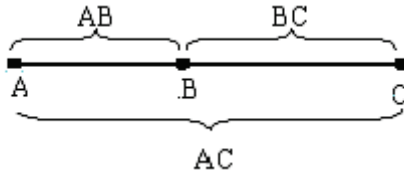

(2) Obtain the instrument constant by repeat measurement,

$$\text{Instrument constant} = AB + BC - AC$$

(3) When there is error between written instrument constant value and calculated value, only need to synthesize the instrument constant and prism constant, and then input the synthesized data in prism constant form, please refer to "7.3.1 Setting of the prism constant".

(4) Once again, measure at a calibrated baseline and compare results.

(5) If using above procedure a difference of over 5mm is found, the instrument constant need reset as the operating procedure on next page.

Operating procedure	Operation	Display
<p>① Press the [F1] key and power [①] key at the same time to enter service menu.</p> <p>② Press the [F1] key, and input the password 1120, press the [F4] key to confirm.</p> <p>③ Press the [F2] key.</p> <p>④ Press the [F1] key.</p> <p>⑤ Press the [F1] key to input new constant, press the [F4] to confirm.</p> <p>⑥ Press the [F3] (YES) key. Press any key, the instrument finish setting and power off automatically. ※1)</p>	[F1]+	<pre>PASSWORD INPT --- --- ENT</pre>
	[①]	
	[F1]	
	[1120]	
	[F4]	<pre>ADJUSTMENT MODE F1: V INDEX ADJ. F2: INST. CONST F3: SET DEFAULT!!</pre>
	[F2]	<pre>INST. CONST SET CONST: 000mm</pre>
	[F1]	<pre>INPT --- --- ENT</pre>
[F1]	<pre>INST. CONST SET CONST: 0002_ mm</pre>	
input	<pre>--- --- CLR ENT</pre>	
constant	<pre>INST. CONST SET CONST:0008 mm SET?</pre>	
[F4]	<pre>--- --- YES NO</pre>	
[F3]	<pre>INST. CONST SET CONST:0008 mm SET?</pre>	
Any key	<pre>Waiting... [NO] Save Ok!</pre>	
<p>※1) Press the [F4](NO) key to cancel the setting.</p>		

13.2 Checking/adjusting the plate level

(1) Set the instrument on stable device (such as tripod or adjusting table) and fix it.

(2) Level the instrument roughly, place the plate level parallel to a join-line of two leveling screws, say, A and B. Use these two leveling screws only and place the bubble in the center of the plate level.

(3) Rotate the instrument 180° and check bubble movement of the plate level. If the bubble has always been in the center of the plate level, then it is not needed to adjust. If the bubble has been displaced (deviate the center away half of one grid), then adjust it.

Adjustment

(1) Set the instrument on stable device and fix it.

(2) Level the instrument roughly.

(3) Place the plate level parallel to a join-line of two leveling screws. Use these two leveling screws only and place the bubble in the center of the plate level.

(4) Rotate the instrument 180° . When the bubble stable, adjust the level adjustment screw with the adjusting pin and return the bubble towards the center of the plate level. Correct only one-half of the displacement by this method.

(5) Repeat the procedures of (3) and (4) until anywhere the instrument moves to, the bubble will always be in the center of the plate level.

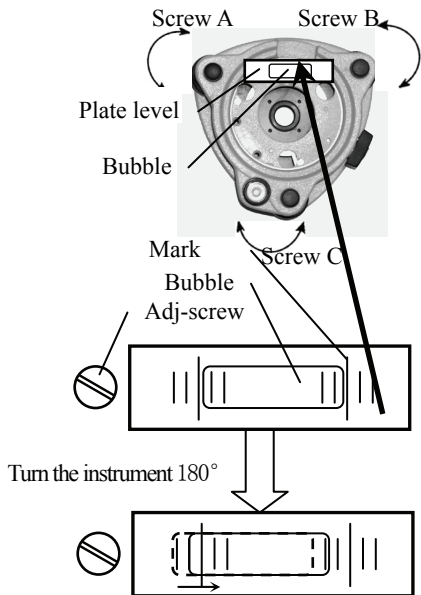

13.3 Checking/adjusting the circular level Check

- (1) Set the instrument on stable device and fix it;
- (2) Precisely level the instrument with the plate level;
- (3) Look the bubble of the circular level whether is in the center; if the bubble is centered properly, adjustment is not required. Otherwise, adjust it.

Adjustment

- (1) Set the instrument on stable device and fix it;
- (2) Precisely level the instrument with the plate level;
- (3) Shift the bubble to the center of the circular level, by adjusting two adjustment screws with the adjusting pin.

NOTE: When adjust with pin, you should do that with smaller strength, the loose-tight degree of two screws should be similar.

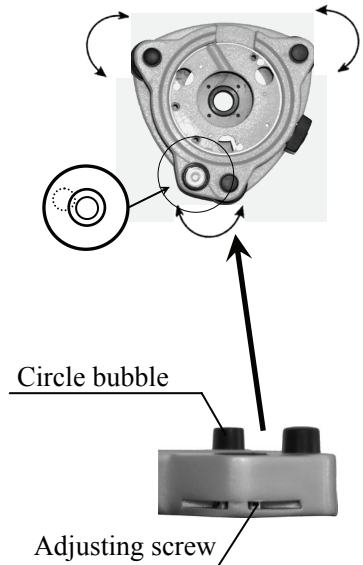

13.4 Checking/adjusting the optical sight

Check

- (1) Set the instrument on stable device and fix it;
- (2) Set a cross mark front the instrument 50m apart;
- (3) Let the telescope collimate the cross mark;
- (4) Observe the optional sight collimator whether collimating the cross mark, if collimates the mark, adjusting is not required. Otherwise, adjusting is not required. Otherwise, adjust it.

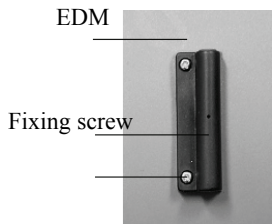

Adjustment

- (1) Set the instrument on stable device and fix it;
- (2) Set a cross mark front the instrument 50m apart;
- (3) Let the telescope collimate the cross mark;
- (4) Loose two fixed screws of optional sight and adjust them, when the optional sight on proper place fix the two fixed screws.

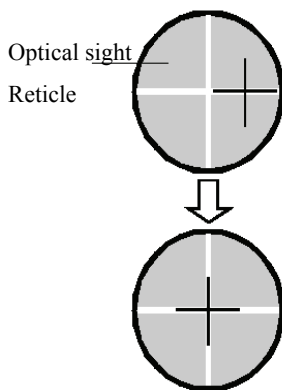

13.5 Checking/Adjusting the plummet

13.5.1 Checking/Adjusting the optical plummet Check

(1) Set the instrument on stable device and fix it.

(2) Set a cross mark under the instrument.

(3) Use the three leveling screws and coincide the center mark of plummet and cross mark on the ground.

(4) Rotate the instrument 180° around and check the center mark and cross mark, if they are coincide, adjustment is not required. Otherwise, adjust it.

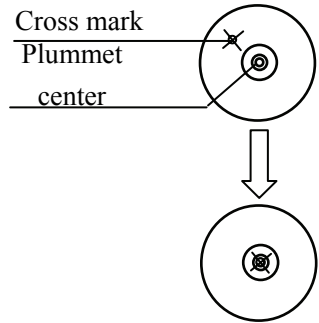

Adjustment

(1) Set the instrument on stable device and fix it.

(2) Set a cross mark under the instrument.

(3) Use the three leveling screws and coincide the center mark of plummet and cross mark on the ground.

(4) Rotate the instrument 180° around and take off the cover of the optical plummet eyepiece, adjust the four adjusting screws with the adjusting pin to shift the center mark to the cross mark, correct only one-half of the displacement in this manner.

(5) Repeat the operation in (3) and (4) until coincide the center mark of the plummet and cross mark on the ground.

13.5.2 Checking/Adjusting the laser plummet (Optional accessory)

Check

- (1) Set the instrument on stable device and fixes it;
- (2) Set a cross mark on the ground under the instrument;
- (3) Turn the three leveling screws until the instrument keeps leveling and the laser spot coincides with the cross mark on the ground;
- (4) Rotate the instrument 180° (200g) around and check the laser spot and cross mark, if they are coincide, adjustment is not required. Otherwise, adjust it.

Adjustment

- (1) Set the instrument on stable device and fixes it;
- (2) Set a cross mark on the ground under the instrument;
- (3) Turn the three leveling screws until the instrument keeps leveling and the laser spot coincides with the cross mark on the ground;
- (4) Rotate the instrument 180° (200g) around and take off the protecting cover of the laser plummet, adjust the four adjusting screws with the screwdriver to move the laser spot to the cross mark, correct only one-half of the displacement in this manner.
- (5) Repeat the operation in (3) and (4) until the instrument keeps leveling and the laser spot coincides with the cross mark when rotating alidade of instrument to any direction.

13.6 Checking/Adjusting the vertical cross-hair on telescope

(1) Set the instrument up on the tripod and carefully level it.

(2) Set a point A in front of the instrument 50m apart;

(3) Collimate the point A and adjust the vertical tangent screw; if the point appears to move continuously on the hair, adjustment is not required. Otherwise, adjust it.

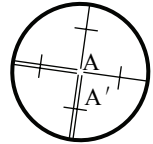
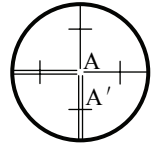

Adjustment

(1) Set the instrument, and set the point A in front of the instrument 50m apart.

(2) Take off cover of telescope eyepiece, rotate the vertical tangent screw and loosen all four adjusting screws slightly with the cross screw-driver, then revolve the eyepiece section so that the vertical cross-hair coincides to point A, finally, re-tighten the four screws.

(3) Repeat the operation in check (3) and adjusting (2) until there is no deviation.

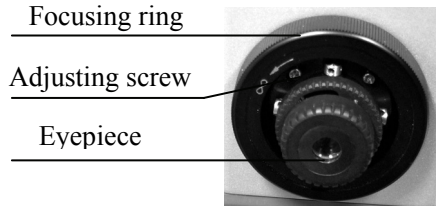

13.7 Checking/adjusting horizontal collimation error Check

- (1) Set-up the instrument on tripod or adjustment platform and leveling accurately;
- (2) Aim at the cross-hairs of collimator or the obvious target at a distance. Get the face left angle reading H_l and the face right angle reading H_r .
- (3) Calculating the horizontal collimation error C according to $C = (H_l - H_r \pm 180^\circ) / 2$ if $C < 8''$, no adjustment will be necessary. If $C > 8''$, proceed with the following adjustment.

Adjustment

- (1) Rotate the instrument in face right position, turning horizontal tangent screw until $H_r' = H_r + C$.
- (2) Loosen the shield of telescope's reticule adjusting two screws at left and at right until the vertical hairs of telescope's reticule coincides with the cross-hairs of collimator or target.
- (3) Repeat the check and adjustment procedure until it is up to standard.

13.8 Checking/adjusting of the vertical index error i .

Finish the adjustment of the across-hair and the error $2C$, and then begin this adjustment.

Finish the adjustment of the across-hair and the error $2C$, and then begin this adjustment.

Check

- (1) Set-up the instrument on tripod or adjustment platform and leveling accurately.
- (2) Aim at the cross-hairs of collimator or the obvious target at a distance, which should be about $\pm 10^\circ$ away from the horizon. Read the face left angle reading V_l and the face right angle reading V_r .
- (3) Calculating the vertical index error $i = (V_l + V_r - 360^\circ) / 2$.
- (4) If $i < 10''$, adjustment is not required. Otherwise, adjust it.

Adjustment

If the vertical index I is too bigger, using program to adjust.

Operating procedure	Operation	Display
① Press the [F1] key and [①] power key at same time. ※1)	[F1]+[①]	<div style="border: 1px solid black; padding: 5px;"> PASSWORD: INPT --- --- ENT </div>
② Press the [F1] key to input the password 1120, press [F4] key to confirm.	[F1] [1120] [F4]	<div style="border: 1px solid black; padding: 5px;"> ADJUSTMENT MODE F1: V INDEX ADJ. F2: INST. CONST F3: SET DEFAULT!! </div>
③ Press the [F1] key.	[F1]	<div style="border: 1px solid black; padding: 5px;"> V INDEX ADJ. <STEP-1> FACE 1 VZ: 95° 22' 04" <div style="text-align: right;">ENT</div> </div>
④ Rotate the telescope about one circle.	Initialization	<div style="border: 1px solid black; padding: 5px;"> V INDEX ADJ. <STEP-2> FACE 2 VZ: 275° 40' 04" <div style="text-align: right;">ENT</div> </div>
⑤ At face-left collimate the reticule of collimator, press the [F4] key to confirm. ※2)※3)	[F4] collimate (Left)	<div style="border: 1px solid black; padding: 5px;"> V INDEX ADJ. VI: -5° 22' 04" SET? <div style="text-align: right;">YES NO</div> </div>
⑥ At face-right collimates the reticule of collimator, press the [F4] key to confirm.	[F4] collimate (Right)	<div style="border: 1px solid black; padding: 5px;"> V INDEX ADJ. VI: -5° 22' 04" SET? Waiting... </div>

<p>⑦ Press the [F4] key to confirm.</p> <p>⑧ Press the [F3](YES) key.※4)</p> <p>⑨ Press any key, the instrument finish the setting and power off automatically.</p>	<p>[F4]</p> <p>[F3]</p> <p>Any key</p>	<div style="border: 1px solid black; padding: 5px; margin-bottom: 10px;"> <p>V INDEX ADJ. VI: -5° 22' 04" SET? Save OK!</p> </div>
<p>※1) Before adjusting the error, set the instrument on tripod or adjustment platform and fix it with column screw, leveling it accurately and open the compensator.</p> <p>※2) The collimator or target will not apart away from horizontal line $\pm 10^\circ$</p> <p>※3) Collimate the target at normal position firstly, and then collimate the target at reverse position, users must operate the instrument according to the displaying information.</p> <p>※4) Press the [F3] key to cancel the setting, and power off automatically.</p>		

13.9 Checking the optical axis

Finish the adjustment of the cross-hairs and the error 2C, then check the coincide of the sight-axis and EDM-axis.

Check

- (1) Set-up a prism at a distance, which should be about 100m away from the instrument.
- (2) Set-up the instrument on tripod or adjustment platform and leveling accurately, then switch on.
- (3) Collimate the center of the prism, measure distance in the way which be introduced in chapter 7.
- (4) If the receiving is well, the buzzer will sound immediately and the measuring result will display in short time, then the adjustment is not requirement.

Adjustment

If the case is different with introduction in (4), please contact with our local dealer.

This check should be do in fine atmospheric conditions

14. Specifications

RTS series

Telescope

Length	156mm
Image	Erect
Magnification	30×
Objective lens	Φ45mm
Field of view	1°30′
Minimum focus	1.0m
Reticle illumination	Yes

Angle measurement

Reading system	Absolute encoder
Angle unit	degree/gon/mil, selectable
Minimum reading	1"/5"/10", selectable
Detecting mode	Both circles adopt diametrical detection
Accuracy	RTS112 "2

Distance measurement

Measuring range (Good condition*)

Single prism	1 to 3000m
Mini-reading	
Fine mode	1mm(0.01ft)
Tracking mode	10mm(0.1ft)
Accuracy	
Prism mode	±(1.5mm+2ppm×D)
Measuring time	Fine/Rapid/Tracking 1.5s/0.9s/0.5s Initial:2.5s

Distance Unit	m/ft selectable
Temperature unit	°C/°F, selectable
Pressure unit	hPa/mmHg/inchHg, selectable

Temperature input range	-40°C to +60°C (1°C steps)
Pressure input range	500hPa to 1500hPa(1hPa steps)
Prism constant condition	-99.9mm to +99.9mm
Refraction and earth curvature correction	OFF/0.14/0.2, selectable
Reflecting prism constant correction	-99.9mm to +99.9mm

Level sensitivity

Plate level	30"/2mm
Circular level	8'/2mm

Compensation

System	Single axis
Working range	± 3'

Optical plummet (Factory optional)

Image	Erect
Magnification	3×
Focusing range	0.5m ~ ∞
Field of view	4°

Laser plummet*²

Accuracy	±1mm/1.5m
Laser class	Class 2(IEC60825-1)
Laser wave length	635nm

Display

Display unit	LCD or OLED(Optional) 4 lines × 16 characters
--------------	--

Memory

Internal memory	128M
-----------------	------

Data communication

I/O	USB&RS-232C(Standard) SD card&Bluetooth (Optional)
-----	---

Power

Battery	3400mAh Li-ion Rechargeable
Voltage	7.4 V DC
Continuous operation time	Approx. 12hours
Chargers	FDJ6-Li (100V to 240V 50/60Hz)
Charging time (at +20°C)	Approx. 4 hours

Others:

CPU	32-bit
EDM technology	Digital signal processing
Dimension	175×178×340mm(W×D×H)
Weight	5.1kg
Water proof	IP66(IEC60529)
Operating temperature	-20°C ~ +50°C
Storage temperature	-40°C ~ +70°C

*¹ **Good condition: no haze, visibility about 30km**

*² **Laser plummet mounted on the bottom of the vertical axis**

OTS series

Telescope

Length	156mm
Image	Erect
Magnification	30×
Objective lens	Φ45mm
Field of view	1°30′
Minimum focus	1.0m
Reticle illumination	Yes

Angle measurement

Reading system	Absolute encoder
Angle unit	degree/gon/mil, selectable
Minimum reading	1"/5"/10", selectable
Detecting mode	Both circles adopt diametrical detection
Accuracy	OTS112 "2

Distance measurement

Laser wave length	650-690nm
Measuring range(Good condition* ¹)	
Reflectorless* ²	
R300	1 to 300m(Standard)
R500	1 to 500m(optional)
Laser class	Class 3R(IEC60825-1)
Reflective sheet/RP30	1 to 800m
Laser class	Class 3R(IEC60825-1)
Single prism	1 to 3000m
Laser class	Class 1(IEC60825-1)
Mini-reading	
Fine mode	1mm(0.01ft)
Tracking mode	10mm(0.1ft)

Accuracy	Initial:2.5s
Prism mode	$\pm(1.5\text{mm}+2\text{ppm}\times\text{D})$
Reflective sheet	$\pm(3\text{mm}+2\text{ppm}\times\text{D})$
Reflectorless	
R300 1.5m-150m: 3mm+2ppm,	$\cong 150\text{m}: \pm(5\text{mm}+2\text{ppm}\times\text{D})$
R500 1.5m-200m: 3mm+2ppm,	$\cong 200\text{m}: \pm(5\text{mm}+2\text{ppm}\times\text{D})$
Measuring time	
Prism	typ. 1.0-1.5s
Reflective sheet/RP30	typ.1.5s
Reflectorless	typ.0.5-2s, max20s
Distance Unit	m/ft selectable
Temperature unit	$^{\circ}\text{C}/^{\circ}\text{F}$, selectable
Pressure unit	hPa/mmHg/inchHg, selectable
Temperature input range	-40°C to $+60^{\circ}\text{C}$ (1°C steps)
Pressure input range	500hPa to 1500hPa (1hPa steps)
Prism constant condition	-99.9mm to $+99.9\text{mm}$
Refraction and earth curvature correction	OFF/0.14/0.2, selectable
Reflecting prism constant correction	-99.9mm to $+99.9\text{mm}$
Level sensitivity	
Plate level	30"/2mm
Circular level	8'/2mm
Compensation	Single axis
System	Liquid type
Working range	$\pm 3'$
Optical plummet (Factory optional)	
Accuracy	$\pm 0.8\text{mm}/1.5\text{m}$
Image	Erect
Magnification	3 \times
Focusing range	0.5 m $\sim \infty$

Field of view	4°
Laser plummet*³	
Accuracy	±1mm/1.5m
Laser class	Class 2(IEC60825-1)
Laser wave length	635nm
Display	
Display unit	LCD or OLED(Optional) 4 lines ×16 characters
Memory	
Internal memory	128M
Data communication	
I/O	USB&RS-232C(Standard) SD card&Bluetooth (Optional)
Power	
Battery	3400mAh Li-ion Rechargeable
Voltage	7.4V DC
Continuous operation time	Approx. 12 hours
Chargers	FDJ6-Li (100V to 240V 50/60Hz)
Charging time (at +20°C)	Approx. 4 hours
Others:	
CPU	32-bit
EDM technology	Digital signal processing
Dimension	175×178×340mm(W×D×H)
Weight	5.1kg
Water proof	IP66(IEC60529)
Operating temperature	-20°C ~ +50°C
Storage temperature	-40°C ~ +70°C

***¹ Good condition: no haze, visibility about 30km**

***² Technical Data for OTS series EDM Reflectorless Measurement Range**

Option	Kodak Gray Card	Range D	Range E	Range F
		m	m	m
R300	White side, 90% reflective	200	250	300
	Gray side, 18% reflective	100	120	150
R500	White side, 90% reflective	300	400	500
	Gray side, 18% reflective	150	200	250

Atmospheric Conditions

D: Object in strong sunlight, severe heat shimmer

E: Object in shade, sky overcast

F: Underground, night and twilight

***³ Laser plummet mounted on the bottom of the vertical axis**

15. Packing list

●Carrying case	1each
●Instrument	1each
●Battery	2 each
●Charger	1 each
●Tool kit	1each
●Instruction manual	1each
●Disc	1 each
●Communication cable(D30-2200)	1 each
●Reflective sheet (only for OTS series)	2 each

Attachment 1: atmospheric correction formula and chart (for your reference)

Factory setting: temperature: 20°C, pressure:1013hPa, 0ppm

The correction:

$$K_{pt} = 274.417 - 0.2904 * p / (1 + 0.0036 * t) \dots \dots \dots \text{RTS}$$

$$K_{pt} = 278.960 - 0.2904 * p / (1 + 0.0036 * t) \dots \dots \dots \text{OTS}$$

Where: p--Pressure value (hPa)

t--Temperature value (°C)

K_{pt}--Atmospheric correction (ppm)

Example:

t=20°C, p=1013hpa, L0=1000m.

Then: K_{pt}=0ppm (RTS)

K_{pt}=4ppm (OTS)

$$L = L_0(1 + K_{pt}) = 1000 \times (1 + 0 \times 10^{-6}) = 1000.000\text{m (RTS)}$$

$$L = L_0(1 + K_{pt}) = 1000 \times (1 + 4 \times 10^{-6}) = 1000.004\text{m (OTS)}$$

The atmospheric value is obtained easily with the atmospheric correction chart. Find the measured temperature in horizontal axis, and pressure in vertical axis on the chart.

Read the value from the diagonal line, which is the required atmospheric correction value.

For RTS series

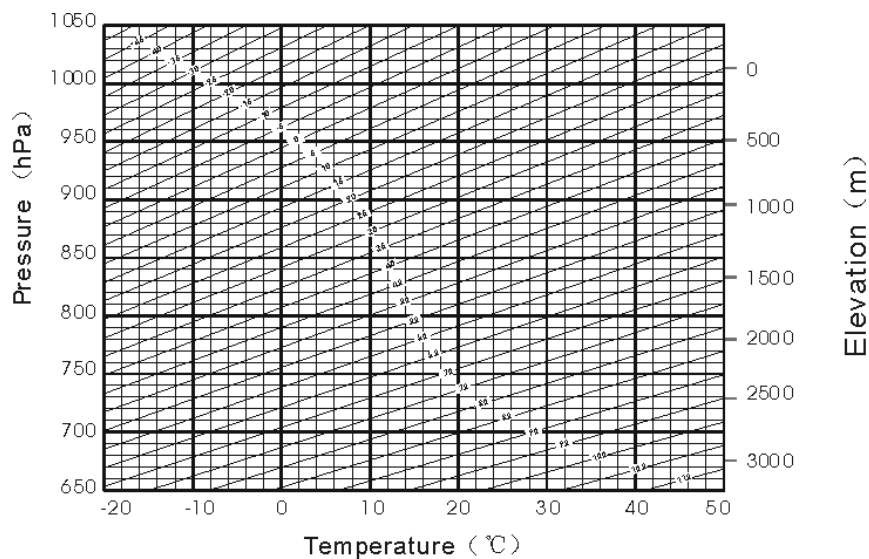

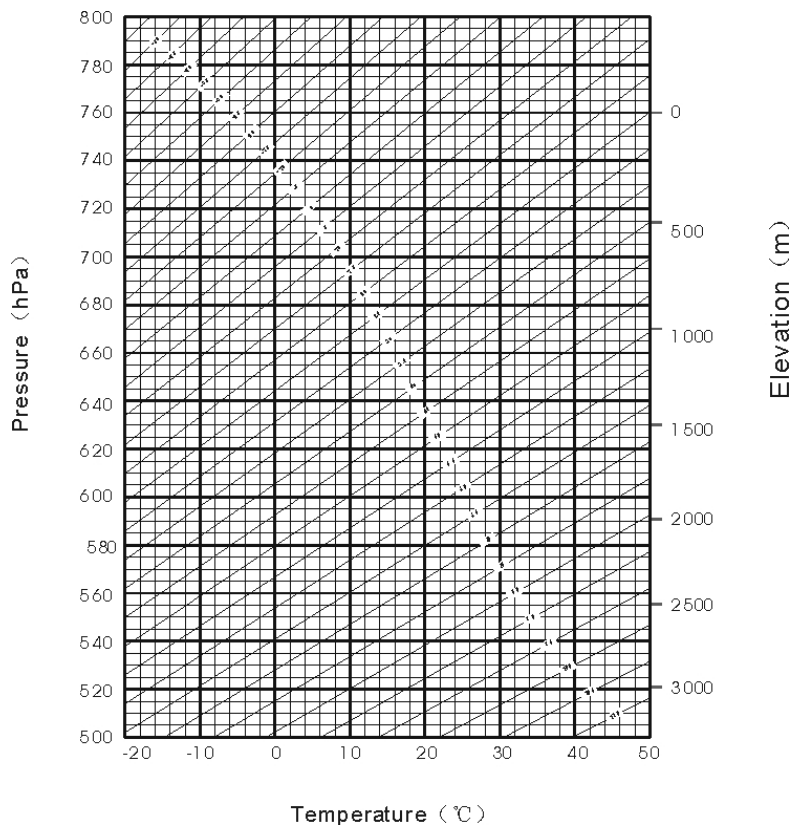

For OTS series

Attachment 2 Correction for refraction and earth curvature

Horizontal distance and vertical distance calculation formula: with correction for refraction and earth curvature taken into account:

Horizontal distance: $D=AC$ (α) or BE (β)

Vertical distance: $Z=BC$ (α) or EA (β)

$D=L\{\cos\alpha - (2\theta - \gamma)\sin\alpha\}$

$Z=L\{\sin\alpha + (\theta - \gamma)\cos\alpha\}$

$\theta = L * \cos\alpha / 2R$ Earth curvature correcting item

$\gamma = K * L \cos\alpha / 2R$ Atmospheric refraction correcting item

$K=0.14$ or 0.20 Coefficient of refraction

$R=6372\text{km}$ Radius of earth

α (or β)Altitude angle L Slope distance

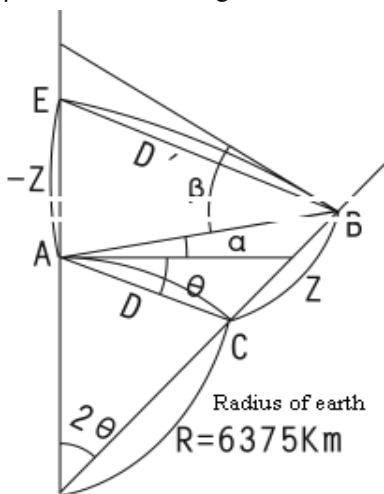

The conversion formula for horizontal and vertical distance is as follows when correction for refraction and earth curvature is not applied:

$HD=L \cos\alpha$

$VD=L \sin\alpha$

Attached file 3: communication instruction and data format

1) Communication parameters setting

BAUD RATE (Baud rate): 2400/4800/9600/19200/38400

PARITY (Parity mode)NONE/ODD/EVEN

DATA BITS (Data length): 7/8

STOP BITS (Stop bit): 0/1/2

PROTOCOL(Protocol): XON/XOFF, NONE

2) Data format

Uploading coordinate data format

| C1 | C2 | C3 | ... | Cn | CR | LF |

C1-Cn:

PT#,X,Y,Z,PCODE

NOTE: there is no blank after comma

Example:

101,994.815,1000,987,100.113,STN

CR(ODH) and LF(OAH) at the ending of data block, means the ending mark of data block

Downloading data format:

CONTROL WORD field1.....fieldn

CONTROL WORD, with blank to finish

field1 to fieldn-1 with comma to finish

fieldn with CR(ODH) and LF(OAH) to finish

Control code and attached information:

JOB Job name, description

NAME Surveyor name

INST Description of instrument model

UNITS meter/feet, degree/gon

SCALE Grid factor, scale factor, elevation

ATMOS Temperature, pressure

STN PT#, instrument height, PCODE

XYZ X (N coordinate), Y(E coordinate), Z(elevation)

BKB PT#, azimuth of backsight point, angle of backsight point

BS PT#[. target height]

FS PT# target height, PCODE[, serial code]

SS PT# target height, PCODE[, serial code]

CTL control code[, point code 2[, serial code2](Select one optionally)

HV HA (Horizontal angle), VA(vertical angle)

SD HA (Horizontal angle), VA(Vertical angle), SD(Slope distance)

HD HA (Horizontal angle), HD(Horizontal distance), VD(height difference)

OFFSET Radial offset, tangent offset, vertical offset

PTL_OFF offset on the reference line direction, offset on the line
which is cross at right angles with reference line

NOTE Note content

NOTE:

These designs, figures and specifications are subject to change without notice. We shall not be held liable for damages resulting from errors in this instruction manual.



Suzhou FOIF Co., Ltd.

TEL: +86-512-65224904

FAX: +86-512-65230619

[http:// www.foif.com.cn](http://www.foif.com.cn)

E-mail: internationalsales@foif.com.cn

